

RIDUTTORI PENDOLARI
SHAFT MOUNTED GEARBOXES

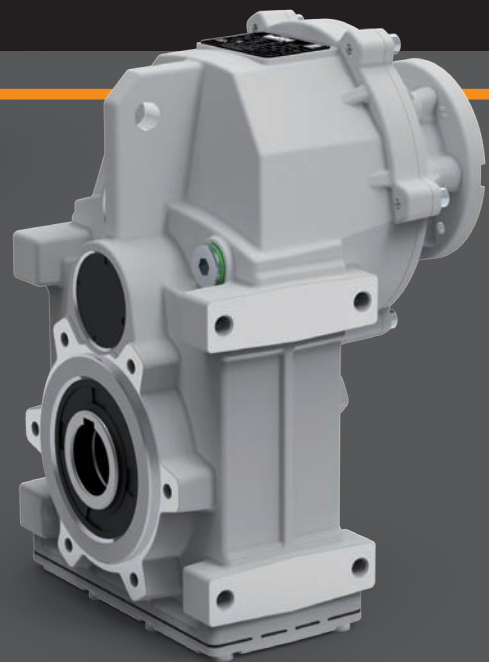

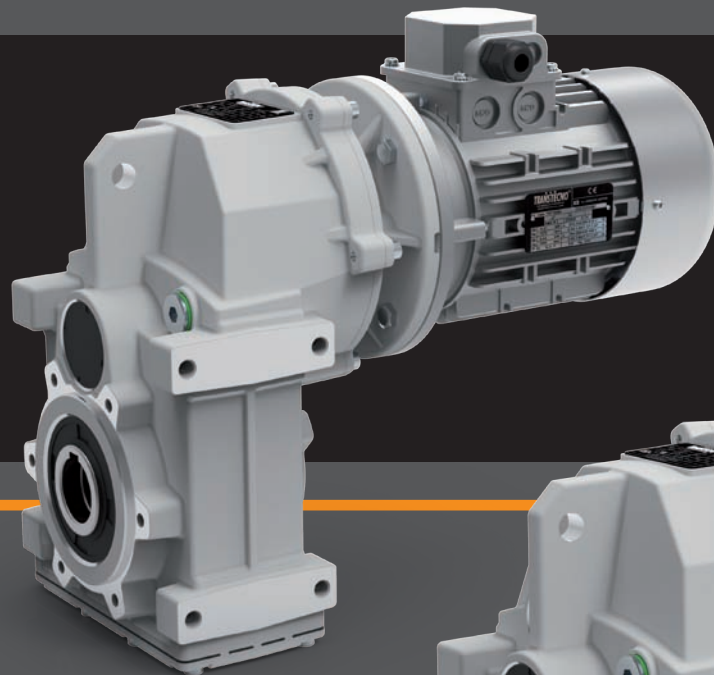

Indice	Index	Pag. Page
Caratteristiche tecniche	<i>Technical features</i>	D2
Designazione	<i>Classification</i>	D3
Sensi di rotazione	<i>Direction of rotation</i>	D4
Simbologia	<i>Symbols</i>	D4
Lubrificazione	<i>Lubrication</i>	D4
Carichi radiali	<i>Radial loads</i>	D5
Dati tecnici	<i>Technical data</i>	D6
Dimensioni	<i>Dimensions</i>	D12
Accessori	<i>Accessories</i>	D16

ATS

Questa sezione annulla e sostituisce ogni precedente edizione o revisione. Qualora questa sezione non Vi sia giunta in distribuzione controllata, l'aggiornamento dei dati ivi contenuto non è assicurato. **In tal caso la versione più aggiornata è disponibile sul nostro sito internet www.transtecno.com**

This section replaces any previous edition and revision. If you obtained this catalogue other than through controlled distribution channels, the most up to date content is not guaranteed. In this case the latest version is available on our web site www.transtecno.com



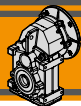

Caratteristiche tecniche

I riduttori pendolari della serie ATS sono caratterizzati da un elevato grado di modularità: partendo da un corpo di base è possibile configurarlo secondo le esigenze con diversi kit in entrata ed in uscita.

Caratteristiche comuni a tutta la serie:

- Carcassa e flangia PAM in pressofusione di alluminio
- Lubrificazione permanente con olio sintetico.
- Flange di uscita in ghisa.

Technical features

The high degree of modularity is a design feature of ATS shaft mounted range. It is possible to set up the version required by using input and output kits.

The main features of CMG range are:

- *Die-cast aluminum housings and input flanges*
- *Permanent synthetic oil long-life lubrication.*
- *Cast iron output flanges.*

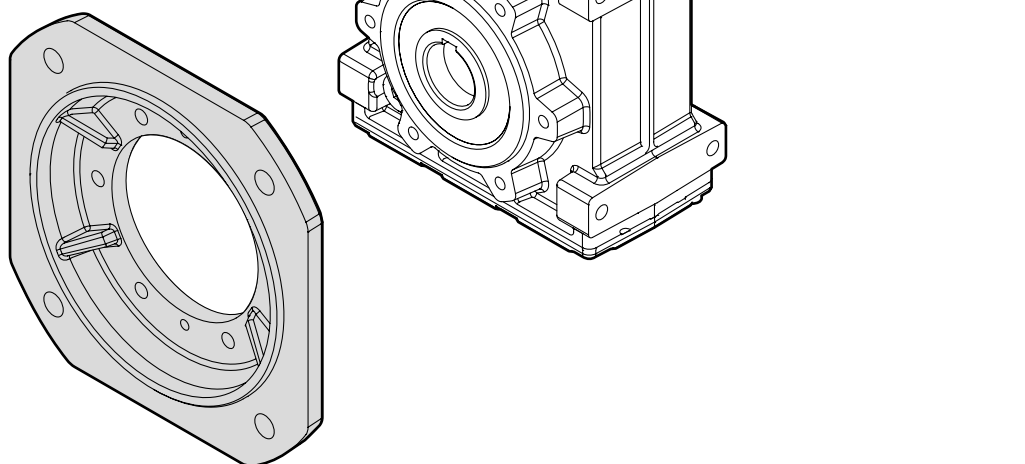

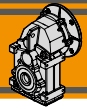

Designazione

Classification

Versione Riduttore
Gearbox Version

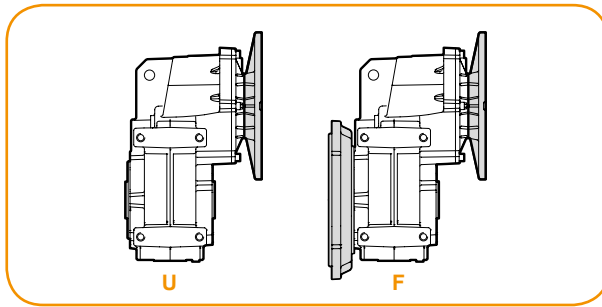

Albero di uscita
Output shaft

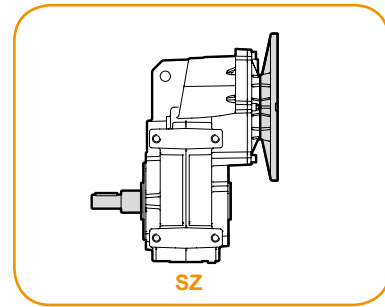

RIDUTTORE / GEARBOX

ATS	90	2	U	29.65	D35	90	B5	SZ
Tipo Type	Grandezza Size	Stadi Stages	Versione Version	Rapporto Ratio	Albero uscita Output shaft	IEC 	Forma costruttiva Version	Albero uscita maschio Solid output shaft
ATS 	90 91	2 3	U... F...	vedi tabelle see tables	vedi tabelle see tables	63.. — 112..	B5 B14	SZ

Versione Riduttore
Gearbox Version

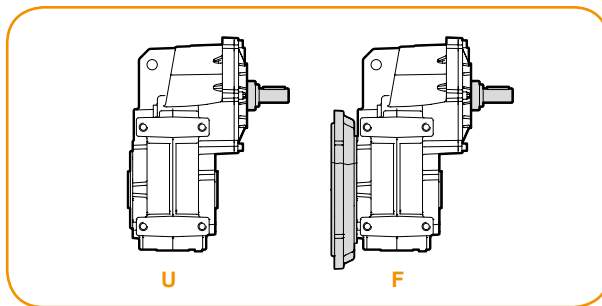

Albero di uscita
Output shaft

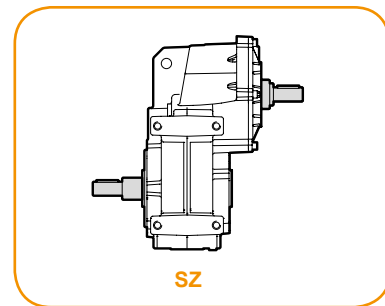

RIDUTTORE / GEARBOX

ATSIS	90	2	U	29.65	D35	SZ
Tipo Type	Grandezza Size	Stadi Stages	Versione Version	Rapporto Ratio	Albero uscita Output shaft	Albero uscita maschio Solid output shaft
ATSIS 	90 91	2 3	U... F...	vedi tabelle see tables	vedi tabelle see tables	SZ

MOTORE / MOTOR

0.75kW	4p	3ph	230/400V	50Hz	T1
Potenza Power	Poli Poles	Fasi Phases	Tensione Voltage	Frequenza Frequency	Pos. morsettiera Terminal box pos.
vedi tabelle see tables	2p 4p 6p 8p	1ph 3ph	230V 230/400V	50Hz 60Hz	T1 (Std)

ATS

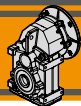

Sensi di rotazione

Direction of rotation

ATS...2
ATSIS..2

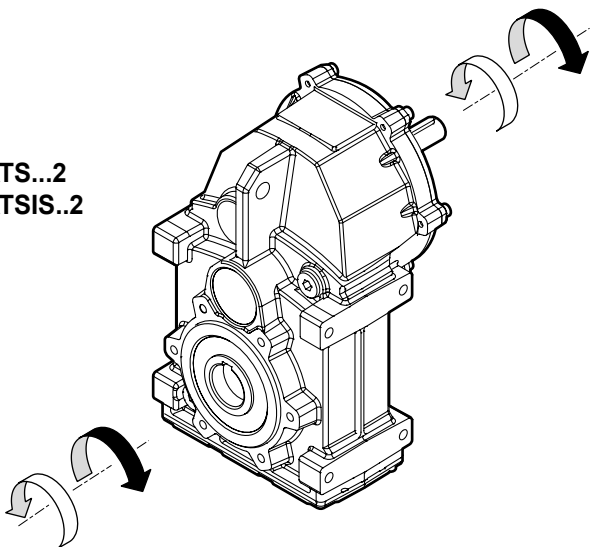

ATS...3
ATSIS..3

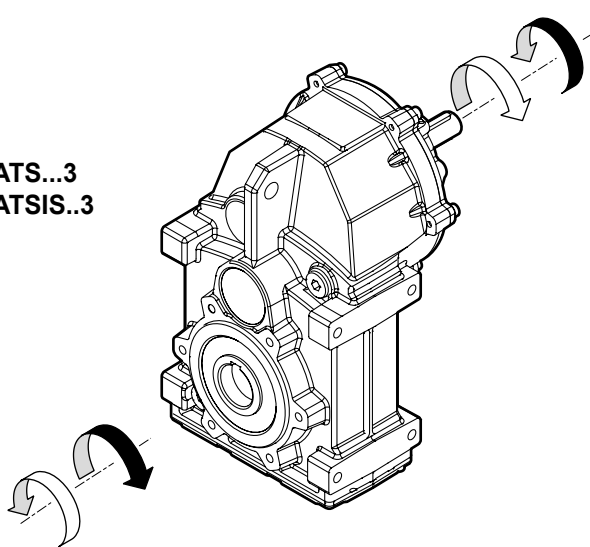

Simbologia

Symbols

n_1	[min ⁻¹]	Velocità in ingresso / <i>Input speed</i>
n_2	[min ⁻¹]	Velocità in uscita / <i>Output speed</i>
i		Rapporto di riduzione / <i>Ratio</i>
P_1	[kW]	Potenza in entrata / <i>Input power</i>
M_2	[Nm]	Coppia nominale in uscita in funzione di P_1 / <i>Output torque referred to P_1</i>
P_{n1}	[kW]	Potenza nominale in entrata / <i>Nominal input power</i>
M_{n2}	[Nm]	Coppia nominale in uscita in funzione di P_{n1} / <i>Nominal output torque referred to P_{n1}</i>
sf		Fattore di servizio / <i>Service factor</i>
R_2	[N]	Carico radiale ammissibile in uscita / <i>Permitted output radial load</i>
A_2	[N]	Carico assiale ammissibile in uscita / <i>Permitted output axial load</i>

Lubrificazione

Lubrication

Tutti i riduttori sono forniti completi di lubrificante sintetico viscosità 320, pertanto possono essere installati in qualunque posizione di montaggio e non necessitano di manutenzione.

Permanent synthetic oil long-life lubrication (viscosity grade 320) makes it possible to use the gearboxes in all mounting positions; for this reason they can be installed in any assembly position and do not require maintenance.



Carichi radiali

Radial loads

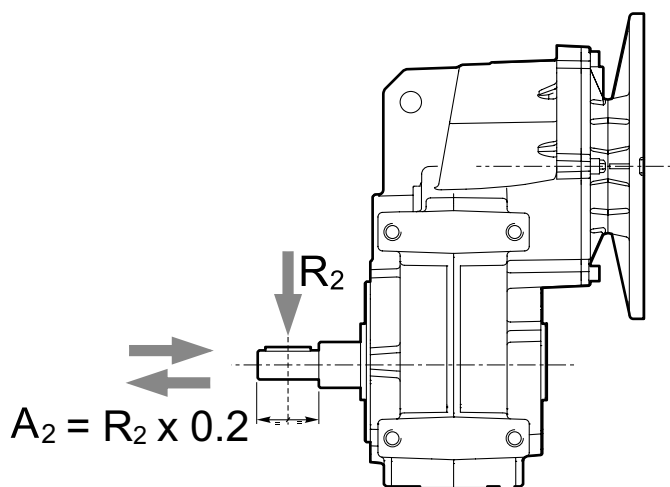

n_2 [min ⁻¹]	R_2 [N]	
	ATS 902 ATS 903	ATS 912 ATS 913
240	2400	3600
180	2400	4200
150	2400	4200
120	2500	4600
100	2800	4800
85	3090	5100
70	3150	5250
55	3630	6000
40	4440	6900
30	5100	7800
20	6000	9500
15	6000	10000
10	6000	10000
5	6000	10000

ATS

Quando il carico radiale risultante non è applicato sulla mezza-
ria dell'albero occorre calcolare quello effettivo con la seguente
formula:

When the resulting radial load is not applied on the centre line
of the shaft it is necessary to calculate the effective load with the
following formula:

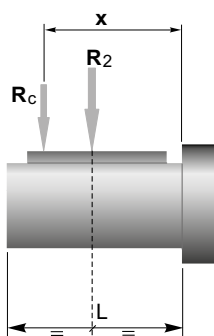

	ATS 902 ATS 903	ATS 912 ATS 913
a	152	174.5
b	97	114.5
R_{2MAX}	6000	10000

$$R_c = \frac{R_2 \cdot a}{(b+x)} \leq R_{2MAX}$$

$$R \leq R_c$$

*a, b = valori riportati nella tabella
a, b = values given in the table*

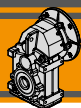

Dati tecnici

n_1 1400 min⁻¹

Technical data

	n_2 [min ⁻¹]	Mn_2 [Nm]	Pn_1 [kW]	i	IEC Motori applicabili IEC Motor adapters					
					71 B5	80 B5/B14	90 B5/B14	100 B5/B14	112 B5/B14	
ATSIS 902										
	239	200	5.2	5.87	B					
	178	250	4.9	7.87	B					
	148	300	4.8	9.47	B					
	121	350	4.6	11.53	B					
	106	350	4.0	13.26	B					
	89.3	350	3.4	15.68	B					
	84.0	350	3.2	16.68	B					*
	73.3	400	3.2	19.09	B					*
	63.7	400	2.8	21.96	B					*
	52.8	400	2.3	26.50	B					*
	50.7	400	2.2	27.61	B					*
	47.2	400	2.1	29.65	B					*
	41.8	400	1.8	33.49	B			*	*	
	39.0	400	1.7	35.87	B			*	*	
	36.6	400	1.6	38.29	B			*	*	
	31.9	400	1.4	43.88	B			*	*	
	28.5	400	1.3	49.09	B			*	*	
	26.6	400	1.2	52.71	B			*	*	
	25.2	400	1.1	55.45	B			*	*	
	22.1	400	0.98	63.41	B			*	*	*
	19.0	400	0.85	73.64	B			*	*	*
	16.0	400	0.71	87.27	B			*	*	*

ATSIS 903					63 B5	71 B5/B14	80 B5/B14	90 B5/B14
	14.0	400	0.62	100.33				*
	11.1	400	0.50	125.89				*
	10.6	400	0.47	131.65				*
	10.0	400	0.45	139.88			*	*
	9.3	400	0.41	151.07			*	*
	8.4	400	0.38	166.13			*	*
	8.1	400	0.36	172.40			*	*
	6.7	400	0.30	208.45			*	*
	6.3	400	0.28	223.41			*	*
	5.6	400	0.25	250.14			*	*
	4.3	400	0.19	323.65		*	*	*
	4.1	400	0.18	345.59		*	*	*
	3.7	400	0.17	376.15		*	*	*

N.B.
Le aree evidenziate indicano l'applicabilità della corrispondente grandezza motore.

B = Boccola di riduzione in acciaio.

 * = Il fattore di servizio (**sf**) deve essere scelto in funzione dell'applicazione: si prega di contattare il nostro Servizio Tecnico.

Prima di eseguire la scelta del motoriduttore riferirsi alle prestazioni elencate nelle tabelle dalla pag. D8 alla pag. D11

N.B.
Highlighted areas indicate motor inputs available on each size of unit.
B = Metal shaft sleeve.

 * = The service factor (**sf**) has to be selected according to the application: please contact our Technical Service.

Before to chose the gearmotor please refer to the performance tables from page D8 up to page D11.

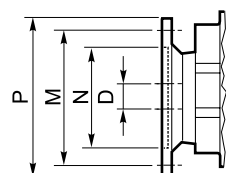

Dimensioni IEC / IEC Dimensions									
	63 B5	71 B5	71 B14	80 B5	80 B14	90 B5	90 B14	100/112 B5	100/112 B14
N	95	110	70	130	80	130	95	180	110
M	115	130	85	165	100	165	115	215	130
P	140	160	105	200	120	200	140	250	160
D	11	14		19		24		28	

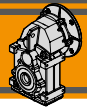

Dati tecnici

n_1 1400 min⁻¹

Technical data

	n_2 [min ⁻¹]	Mn_2 [Nm]	Pn_1 [kW]	i	IEC Motori applicabili IEC Motor adapters					
					71 B5	80 B5/B14	90 B5/B14	100 B5/B14	112 B5/B14	
ATSIS 912										
	245.0	350	9.4	5.71	B					
	183	350	7.0	7.66	B					
	158	400	6.9	8.85	B					
	152	400	6.6	9.22	B					
	125	400	5.4	11.23	B					
	118	400	5.1	11.87	B					
	108	500	5.9	12.92	B					
	98.0	500	5.3	14.29	B					
	86.2	500	4.7	16.24	B					
	80.5	500	4.4	17.39	B					
	70.0	600	4.6	20.01	B					
	66.3	600	4.3	21.10	B					
	55.6	600	3.6	25.16	B					
	54.2	600	3.5	25.81	B					*
	48.5	600	3.2	28.88	B					*
	42.8	600	2.9	32.69	B					*
	37.5	600	2.5	37.30	B					*
	35.0	600	2.3	39.98	B					*
	31.3	600	2.1	44.73	B					*
	27.7	600	1.9	50.53	B			*		*
	24.2	600	1.6	57.77	B			*		*
	20.9	600	1.4	67.09	B			*		*
	17.6	600	1.2	79.52	B			*		*

ATSIS913					63 B5	71 B5/B14	80 B5/B14	90 B5/B14
	17.0	600	1.1	82.28				
	14.9	600	1.0	93.96				
	13.8	600	0.92	101.41				*
	11.4	600	0.76	122.61				*
	10.7	600	0.71	131.41				*
	9.5	600	0.64	147.13				*
	8.9	600	0.60	157.08				*
	7.4	600	0.49	189.92				*
	6.9	600	0.46	203.55			*	*
	6.1	600	0.41	227.91			*	*
	4.7	600	0.32	294.88			*	*
	4.4	600	0.30	314.87			*	*
	4.1	600	0.27	342.72			*	*

N.B.
Le aree evidenziate indicano l'applicabilità della corrispondente grandezza motore.

B = Boccola di riduzione in acciaio.

 * = Il fattore di servizio (**sf**) deve essere scelto in funzione dell'applicazione: si prega di contattare il nostro Servizio Tecnico.

Prima di eseguire la scelta del motoriduttore riferirsi alle prestazioni elencate nelle tabelle dalla pag. D8 alla pag. D11

N.B.
Highlighted areas indicate motor inputs available on each size of unit.
B = Metal shaft sleeve.

 * = The service factor (**sf**) has to be selected according to the application: please contact our Technical Service.

Before to chose the gearmotor please refer to the performance tables from page D8 up to page D11.

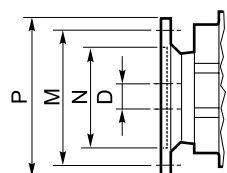



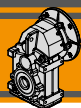

Dimensioni IEC / IEC Dimensions									
	63 B5	71 B5	71 B14	80 B5	80 B14	90 B5	90 B14	100/112 B5	100/112 B14
N	95	110	70	130	80	130	95	180	110
M	115	130	85	165	100	165	115	215	130
P	140	160	105	200	120	200	140	250	160
D	11	14		19		24		28	



Dati tecnici



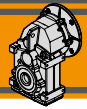

Technical data

P ₁ [kW]	n ₂ [min ⁻¹]	M ₂ [Nm]	sf	i			P ₁ [kW]	n ₂ [min ⁻¹]	M ₂ [Nm]	sf	i		
0.12							0.25						
63A4 (1400 min ⁻¹)	14.0	77	5.2	100.33	ATS903	B5	71A4 (1400 min ⁻¹)	238	10	20.8	5.87	ATS902	B5
	11.1	97	4.1	125.89		B5		178	13	19.4	7.87		B5
	10.6	101	3.9	131.65		B5		148	16	19.3	9.47		B5
	10.0	108	3.7	139.88		B5		121	19	18.5	11.53		B5
	9.3	116	3.4	151.07		B5		106	22	16.1	13.26		B5
	8.4	128	3.1	166.13		B5		89.3	26	13.6	15.68		B5
	8.1	133	3.0	172.40		B5		84.0	27	12.8	16.68		B5
	6.7	160	2.5	208.45		B5		73.3	31	12.8	19.09		B5
	6.3	172	2.3	223.41		B5		63.7	36	11.1	21.96		B5
	5.6	192	2.1	250.14		B5		52.8	43	9.2	26.50		B5
	4.3	249	1.6	323.65	B5	50.7		45	8.8	27.61	B5		
	4.1	266	1.5	345.59	B5	47.2		49	8.2	29.65	B5		
	3.7	289	1.4	376.15	B5	41.8		55	7.3	33.49	B5		
	6.9	157	3.8	203.55	ATS913	B5		39.0	59	6.8	35.87	B5	
	6.1	175	3.4	227.91		B5		36.6	61	6.5	38.29	B5	
	4.7	227	2.6	294.88		B5		31.9	70	5.7	43.88	B5	
	4.4	242	2.5	314.87		B5		28.5	79	5.1	49.09	B5	
	4.4	264	2.3	342.72		B5		26.6	84	4.7	52.71	B5	
						B5		25.2	89	4.5	55.45	B5	
0.18													
63B4 (1400 min ⁻¹)	14.0	116	3.5	100.33	ATS903	B5	14.0	161	2.5	100.33	ATS903	B5/B14	
	11.1	145	2.8	125.89		B5	11.1	202	2.0	125.89		B5/B14	
	10.6	152	2.6	131.65		B5	10.6	211	1.9	131.65		B5/B14	
	10.0	161	2.5	139.88		B5	10.0	224	1.8	139.88		B5/B14	
	9.3	174	2.3	151.07		B5	9.3	242	1.7	151.07		B5/B14	
	8.4	192	2.1	166.13		B5	8.4	266	1.5	166.13		B5/B14	
	8.1	199	2.0	172.40		B5	8.1	276	1.4	172.40		B5/B14	
	6.7	241	1.7	208.45		B5	6.7	334	1.2	208.45		B5/B14	
	6.3	258	1.6	223.41		B5	6.3	358	1.1	223.41		B5/B14	
	5.6	289	1.4	250.14		B5	5.6	401	1.0	250.14		B5/B14	
	4.3	374	1.1	323.65	B5	13.8	163	3.7	101.41	ATS913	B5/B14		
	4.1	399	1.0	345.59	B5	11.4	197	3.1	122.61		B5/B14		
	3.7	434	0.9	376.15	B5	10.7	211	2.8	131.41		B5/B14		
	9.5	170	3.5	147.13	ATS913	B5	9.5	236	2.5		147.13	B5/B14	
	8.9	181	3.3	157.08		B5	8.9	252	2.4		157.08	B5/B14	
	7.4	219	2.7	189.92		B5	7.4	304	2.0		189.92	B5/B14	
	6.9	235	2.6	203.55		B5	6.9	326	1.8		203.55	B5/B14	
	6.1	263	2.3	227.91		B5	6.1	365	1.6		227.91	B5/B14	
	4.7	340	1.8	294.88		B5	4.7	473	1.3		294.88	B5/B14	
	4.4	363	1.7	314.87		B5	4.4	505	1.2		314.87	B5/B14	
4.1	396	1.5	342.72	B5		4.1	549	1.1	342.72	B5/B14			



Dati tecnici

Technical data



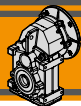

P_1 [kW]	n_2 [min ⁻¹]	M_2 [Nm]	sf	i			P_1 [kW]	n_2 [min ⁻¹]	M_2 [Nm]	sf	i		
0.37							0.55						
71B4 (1400 min ⁻¹)	239	14	14.1	5.87	ATS902	B5	80A4 (1400 min ⁻¹)	239	21	9.5	5.87	ATS902	B5/B14
	178	19	13.1	7.87		B5		178	28	8.8	7.87		B5/B14
	148	23	13.1	9.47		B5		148	34	8.8	9.47		B5/B14
	121	28	12.5	11.53		B5		121	42	8.4	11.53		B5/B14
	106	32	10.9	13.26		B5		106	48	7.3	13.26		B5/B14
	89.3	38	9.2	15.68		B5		89.3	56	6.2	15.68		B5/B14
	84.0	40	8.7	16.68		B5		84.0	60	5.8	16.68		B5/B14
	73.3	46	8.6	19.09		B5		73.3	69	5.8	19.09		B5/B14
	63.7	53	7.5	21.96		B5		63.7	79	5.1	21.96		B5/B14
	52.8	64	6.2	26.50		B5		52.8	95	4.2	26.50		B5/B14
	50.7	67	6.0	27.61		B5		50.7	99	4.0	27.61		B5/B14
	47.2	72	5.6	29.65		B5		47.2	107	3.7	29.65		B5/B14
	41.8	81	4.9	33.49		B5		41.8	121	3.3	33.49		B5/B14
	39.0	87	4.6	35.87		B5		39.0	129	3.1	35.87		B5/B14
	36.6	91	4.4	38.29		B5		36.6	135	3.0	38.29		B5/B14
	31.9	104	3.8	43.88		B5		31.9	155	2.6	43.88		B5/B14
	28.5	116	3.4	49.09		B5		28.5	173	2.3	49.09		B5/B14
	26.6	125	3.2	52.71		B5		26.6	186	2.2	52.71		B5/B14
	25.2	132	3.0	55.45		B5		25.2	196	2.0	55.45		B5/B14
	22.1	150	2.7	63.41		B5		22.1	224	1.8	63.41		B5/B14
	19.0	175	2.3	73.64		B5		19.0	260	1.5	73.64		B5/B14
	16.0	207	1.9	87.27		B5		16.0	308	1.3	87.27		B5/B14
	14.0	238	1.7	100.33	ATS903	B5/B14	14.0	354	1.1	100.33	ATS903	B5/B14	
	11.1	299	1.3	125.89		B5/B14	11.1	444	0.9	125.89		B5/B14	
	10.6	312	1.3	131.65		B5/B14	10.6	464	0.9	131.65		B5/B14	
	10.0	332	1.2	139.88		B5/B14							
	9.3	358	1.1	151.07		B5/B14	31.3	158	3.8	44.73	ATS912	B5/B14	
	8.4	394	1.0	166.13		B5/B14	27.7	178	3.4	50.53		B5/B14	
	8.1	409	1.0	172.40		B5/B14	24.2	204	2.9	57.77		B5/B14	
	24.2	137	4.4	57.77	ATS912	B5	20.9	237	2.5	67.09		B5/B14	
	20.9	159	3.8	67.09		B5	17.6	280	2.1	79.52	B5/B14		
	17.6	189	3.2	79.52		B5							
	17.0	195	3.1	82.28	ATS913	B5/B14	17.0	290	2.1	82.28	ATS913	B5/B14	
	14.9	223	2.7	93.96		B5/B14	14.9	331	1.8	93.96		B5/B14	
	13.8	241	2.5	101.41		B5/B14	13.8	358	1.7	101.41		B5/B14	
	11.4	291	2.1	122.61		B5/B14	11.4	432	1.4	122.61		B5/B14	
	10.7	312	1.9	131.41		B5/B14	10.7	463	1.3	131.41		B5/B14	
	9.5	349	1.7	147.13		B5/B14	9.5	519	1.2	147.13		B5/B14	
	8.9	373	1.6	157.08		B5/B14	8.9	554	1.1	157.08		B5/B14	
	7.4	451	1.3	189.92		B5/B14	7.4	670	0.9	189.92		B5/B14	
	6.9	483	1.2	203.55		B5/B14							
	6.1	541	1.1	227.91		B5/B14							
	4.7	700	0.9	294.88	B5/B14								

ATS



Dati tecnici



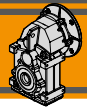

Technical data

P_1 [kW]	n_2 [min ⁻¹]	M_2 [Nm]	sf	i			P_1 [kW]	n_2 [min ⁻¹]	M_2 [Nm]	sf	i		
0.75							1.1						
80B4 (1400 min ⁻¹)	239	29	6.9	5.87	ATS902	B5/B14	90S4 (1400 min ⁻¹)	239	42	4.7	5.87	ATS902	B5/B14
	178	39	6.5	7.87		B5/B14		178	57	4.4	7.87		B5/B14
	148	47	6.4	9.47		B5/B14		148	68	4.4	9.47		B5/B14
	121	57	6.2	11.53		B5/B14		121	83	4.2	11.53		B5/B14
	106	65	5.4	13.26		B5/B14		106	96	3.7	13.26		B5/B14
	89.3	77	4.5	15.68		B5/B14		89.3	113	3.1	15.68		B5/B14
	84.0	82	4.3	16.68		B5/B14		84.0	120	2.9	16.68		B5/B14
	73.3	94	4.3	19.09		B5/B14		73.3	138	2.9	19.09		B5/B14
	63.7	108	3.7	21.96		B5/B14		63.7	158	2.5	21.96		B5/B14
	52.8	130	3.1	26.50		B5/B14		52.8	191	2.1	26.50		B5/B14
	50.7	136	2.9	27.61		B5/B14		50.7	199	2.0	27.61		B5/B14
	47.2	146	2.7	29.65		B5/B14		47.2	214	1.9	29.65		B5/B14
	41.8	164	2.4	33.49		B5/B14		41.8	241	1.7	33.49		B5/B14
	39.0	176	2.3	35.87		B5/B14		39.0	258	1.5	35.87		B5/B14
	36.6	184	2.2	38.29		B5/B14		36.6	270	1.5	38.29		B5/B14
	31.9	211	1.9	43.88	B5/B14	31.9	310	1.3	43.88	B5/B14			
	28.5	236	1.7	49.09	B5/B14	28.5	346	1.2	49.09	B5/B14			
	26.6	253	1.6	52.71	B5/B14	26.6	372	1.1	52.71	B5/B14			
	25.2	267	1.5	55.45	B5/B14	25.2	391	1.0	55.45	B5/B14			
	22.1	305	1.3	63.41	B5/B14	66.3	152	3.9	21.10	ATS912	B5/B14		
	19.0	354	1.1	73.64	B5/B14	55.6	181	3.3	25.16		B5/B14		
	16.0	420	1.0	87.27	B5/B14	54.2	186	3.2	25.81		B5/B14		
	42.8	157	3.8	32.69	ATS912	B5/B14	48.5	204	2.9		28.88	B5/B14	
	37.5	179	3.3	37.30		B5/B14	42.8	231	2.6		32.69	B5/B14	
	35.0	192	3.1	39.98		B5/B14	37.5	263	2.3		37.30	B5/B14	
	31.3	215	2.8	44.73		B5/B14	35.0	282	2.1	39.98	B5/B14		
	27.7	243	2.5	50.53		B5/B14	31.3	315	1.9	44.73	B5/B14		
	24.2	278	2.2	57.77		B5/B14	27.7	356	1.7	50.53	B5/B14		
	20.9	323	1.9	67.09	B5/B14	24.2	407	1.5	57.77	B5/B14			
	17.6	382	1.6	79.52	B5/B14	20.9	473	1.3	67.09	B5/B14			
	17.6	382	1.6	79.52	ATS913	B5/B14	17.6	561	1.1	79.52	B5/B14		
	17.0	396	1.5	82.28		B5/B14	17.0	580	1.0	82.28	ATS913	B5/B14	
	14.9	452	1.3	93.96		B5/B14	14.9	663	0.9	93.96		B5/B14	
13.8	488	1.2	101.41	B5/B14									
11.4	590	1.0	122.61	B5/B14									
10.7	632	0.9	131.41	B5/B14									



Dati tecnici

Technical data

P ₁ [kW]	n ₂ [min ⁻¹]	M ₂ [Nm]	sf	i			P ₁ [kW]	n ₂ [min ⁻¹]	M ₂ [Nm]	sf	i				
1.5							2.2								
90L4 (1400 min ⁻¹)	239	58	3.5	5.87	ATS902	B5/B14	100LA4 (1400 min ⁻¹)	42.8	461	1.3	32.69	ATS912	B5/B14		
	178	77	3.2	7.87		B5/B14		37.5	526	1.1	37.30		B5/B14		
	148	93	3.2	9.47		B5/B14		35.0	564	1.1	39.98		B5/B14		
	121	113	3.1	11.53		B5/B14		31.3	631	1.0	44.73		B5/B14		
	106	130	2.7	13.26		B5/B14									
	89.3	154	2.3	15.68		B5/B14									
	84.0	164	2.1	16.68		B5/B14									
	73.3	188	2.1	19.09		B5/B14									
	63.7	216	1.9	21.96		B5/B14									
	52.8	260	1.5	26.50		B5/B14									
	50.7	271	1.5	27.61	B5/B14										
	47.2	291	1.4	29.65	B5/B14										
	41.8	329	1.2	33.49	B5/B14										
	39.0	352	1.1	35.87	B5/B14										
	36.6	368	1.1	38.29	B5/B14										
	31.9	422	0.9	43.88	B5/B14										
	108.4	127	3.9	12.92	ATS912	B5/B14		245.0	112	3.1	5.71	ATS912	B5/B14		
	98.0	140	3.6	14.29		B5/B14		182.7	151	2.3	7.66		B5/B14		
	86.2	160	3.1	16.24		B5/B14		158.2	174	2.3	8.85		B5/B14		
	80.5	171	2.9	17.39		B5/B14		151.8	181	2.2	9.22		B5/B14		
70.0	197	3.1	20.01	B5/B14		124.7	221	1.8	11.23	B5/B14					
66.3	207	2.9	21.10	B5/B14		117.9	233	1.7	11.87	B5/B14					
55.6	247	2.4	25.16	B5/B14		108.4	254	2.0	12.92	B5/B14					
54.2	254	2.4	25.81	B5/B14		98.0	281	1.8	14.29	B5/B14					
48.5	278	2.2	28.88	B5/B14		86.2	319	1.6	16.24	B5/B14					
42.8	314	1.9	32.69	B5/B14		80.5	342	1.5	17.39	B5/B14					
37.5	359	1.7	37.30	B5/B14	70.0	393	1.5	20.01	B5/B14						
35.0	385	1.6	39.98	B5/B14	66.3	415	1.4	21.10	B5/B14						
31.3	430	1.4	44.73	B5/B14	55.6	494	1.2	25.16	B5/B14						
27.7	486	1.2	50.53	B5/B14	54.2	507	1.2	25.81	B5/B14						
24.2	556	1.1	57.77	B5/B14	48.5	555	1.1	28.88	B5/B14						
						42.8	629	1.0	32.69	B5/B14					
2.2							3.0								
100LA4 (1400 min ⁻¹)	239	85	2.4	5.87	ATS902	B5/B14	100LB4 (1400 min ⁻¹)	239	115	1.7	5.87	ATS902	B5/B14		
	178	113	2.2	7.87		B5/B14		178	155	1.6	7.87		B5/B14		
	148	136	2.2	9.47		B5/B14		148	186	1.6	9.47		B5/B14		
	121	166	2.1	11.53		B5/B14		121	227	1.5	11.53		B5/B14		
	106	191	1.8	13.26		B5/B14		106	261	1.3	13.26		B5/B14		
	89.3	226	1.5	15.68		B5/B14		89.3	308	1.1	15.68		B5/B14		
	84.0	240	1.5	16.68		B5/B14		84.0	328	1.1	16.68		B5/B14		
	73.3	275	1.5	19.09		B5/B14		73.3	375	1.1	19.09		B5/B14		
	63.7	316	1.3	21.96		B5/B14		63.7	431	0.9	21.96		B5/B14		
	52.8	382	1.0	26.50		B5/B14									
	50.7	398	1.0	27.61	B5/B14										
	47.2	427	0.9	29.65	B5/B14										
	245.0	82	4.3	5.71	ATS912	B5/B14		245.0	150	2.3	5.71	ATS912	B5/B14		
	182.7	110	3.2	7.66		B5/B14		182.7	201	1.7	7.66		B5/B14		
	158.2	128	3.1	8.85		B5/B14		158.2	232	1.7	8.85		B5/B14		
	151.8	133	3.0	9.22		B5/B14		151.8	242	1.7	9.22		B5/B14		
	124.7	162	2.5	11.23		B5/B14		124.7	294	1.4	11.23		B5/B14		
	117.9	171	2.3	11.87		B5/B14		117.9	311	1.3	11.87		B5/B14		
	108.4	186	2.7	12.92		B5/B14		108.4	338	1.5	12.92		B5/B14		
	98.0	206	2.4	14.29		B5/B14		98.0	374	1.3	14.29		B5/B14		
86.2	234	2.1	16.24	B5/B14		86.2	425	1.2	16.24	B5/B14					
80.5	251	2.0	17.39	B5/B14		80.5	456	1.1	17.39	B5/B14					
70.0	288	2.1	20.01	B5/B14	70.0	524	1.1	20.01	B5/B14						
66.3	304	2.0	21.10	B5/B14	66.3	553	1.1	21.10	B5/B14						
55.6	362	1.7	25.16	B5/B14	55.6	659	0.9	25.16	B5/B14						
54.2	372	1.6	25.81	B5/B14											
48.5	407	1.5	28.88	B5/B14											
2.2							4.0								
100LA4 (1400 min ⁻¹)	239	154	1.3	5.87	ATS902	B5/B14	112M4 (1400 min ⁻¹)	239	154	1.3	5.87	ATS902	B5/B14		
	178	206	1.2	7.87		B5/B14		178	206	1.2	7.87		B5/B14		
	148	248	1.2	9.47		B5/B14		148	248	1.2	9.47		B5/B14		
	121	302	1.2	11.53		B5/B14		121	302	1.2	11.53		B5/B14		
	106	347	1.0	13.26		B5/B14		106	347	1.0	13.26		B5/B14		
	89.3	411	0.9	15.68		B5/B14		89.3	411	0.9	15.68		B5/B14		
	245.0	150	2.3	5.71		ATS912		B5/B14	245.0	150	2.3		5.71	ATS912	B5/B14
	182.7	201	1.7	7.66				B5/B14	182.7	201	1.7		7.66		B5/B14
	158.2	232	1.7	8.85				B5/B14	158.2	232	1.7		8.85		B5/B14
	151.8	242	1.7	9.22				B5/B14	151.8	242	1.7		9.22		B5/B14
	124.7	294	1.4	11.23	B5/B14			124.7	294	1.4	11.23	B5/B14			
	117.9	311	1.3	11.87	B5/B14			117.9	311	1.3	11.87	B5/B14			
	108.4	338	1.5	12.92	B5/B14			108.4	338	1.5	12.92	B5/B14			
	98.0	374	1.3	14.29	B5/B14			98.0	374	1.3	14.29	B5/B14			
	86.2	425	1.2	16.24	B5/B14			86.2	425	1.2	16.24	B5/B14			
	80.5	456	1.1	17.39	B5/B14			80.5	456	1.1	17.39	B5/B14			
	70.0	524	1.1	20.01	B5/B14	70.0		524	1.1	20.01	B5/B14				
	66.3	553	1.1	21.10	B5/B14	66.3		553	1.1	21.10	B5/B14				
	55.6	659	0.9	25.16	B5/B14	55.6		659	0.9	25.16	B5/B14				

ATS

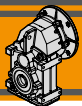

ATS 902

ATS 902 U..

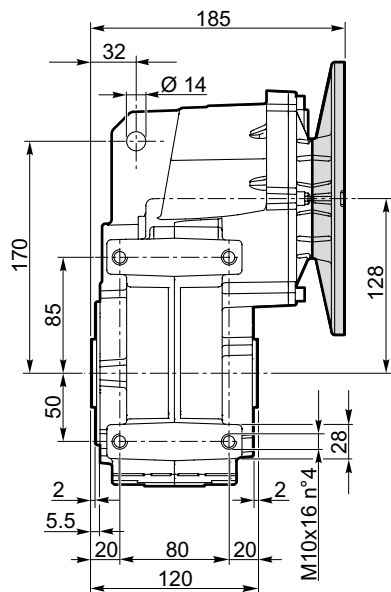

ATSIS 902 U..

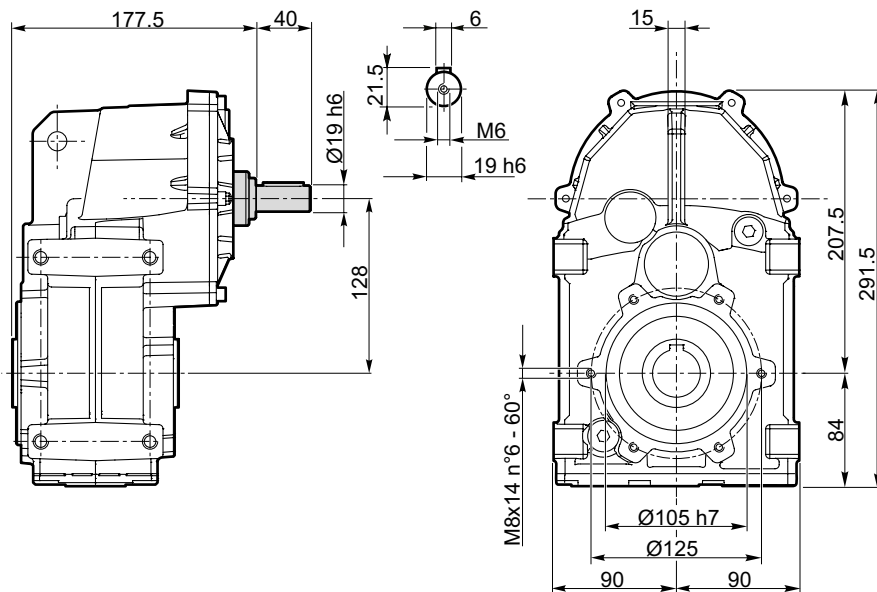

ATS 902 F..

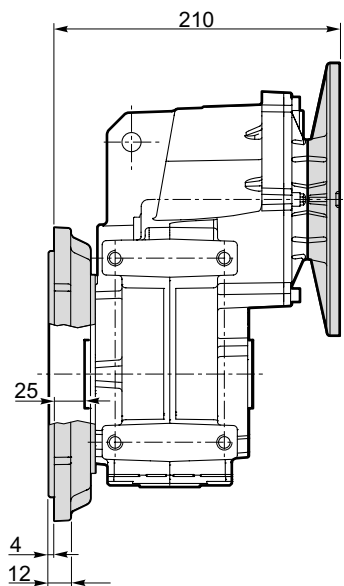

ATSIS 902 F..

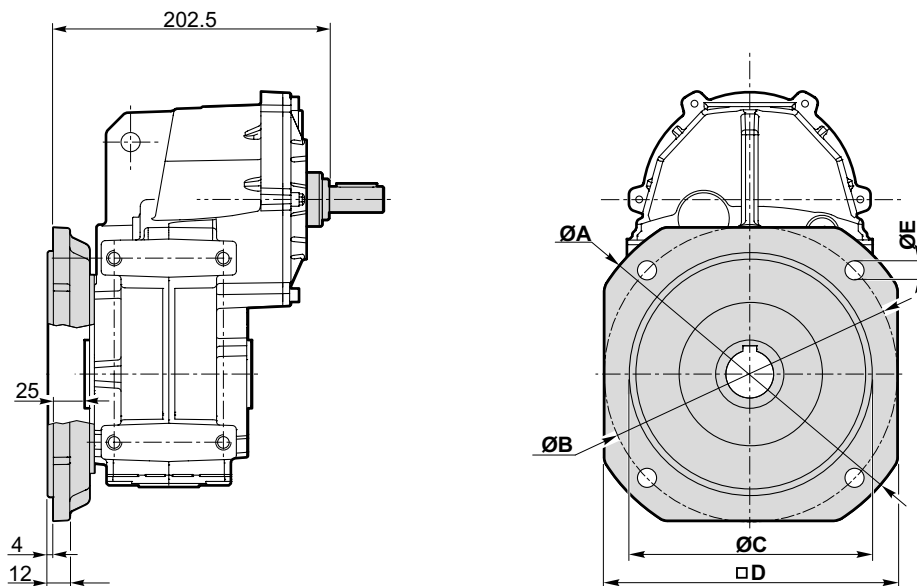

Versione F / F Version							
ATS ATSIS	ØA	ØB	ØC f7	□D	ØE	Flangia / Flange	
						Tipo / Type	Peso / Weight [kg]
902	200	165	130	165	11	F200	2
	250	215	180	215	14	F250	3.2

ATS 902.. D35 - ATSIS 902.. D35

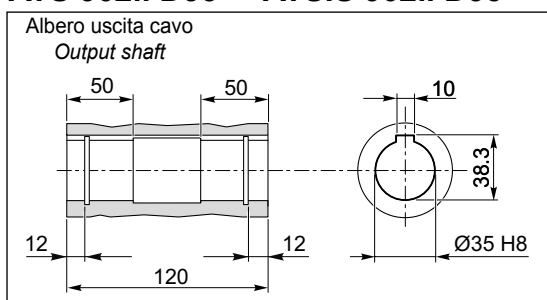

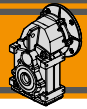

Dimensioni

Dimensions

ATS 903

ATS 903 U..

ATSIS 903 U..

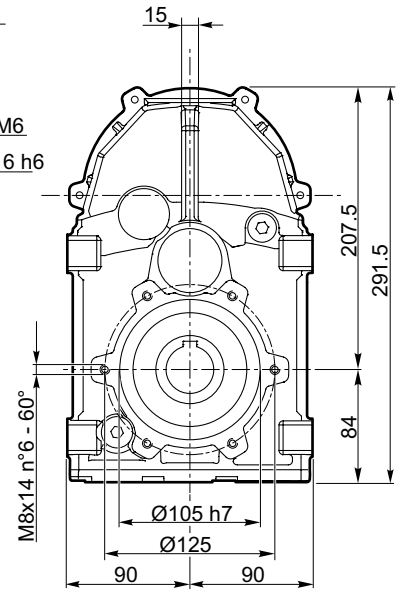
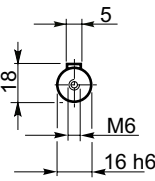
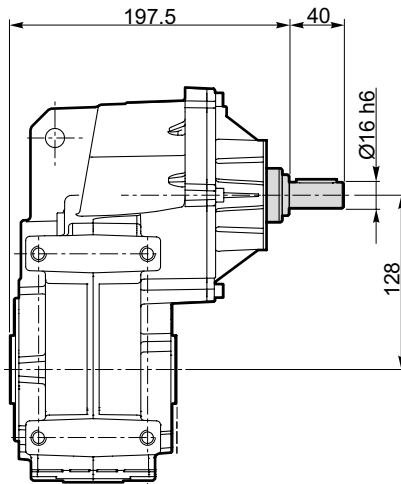
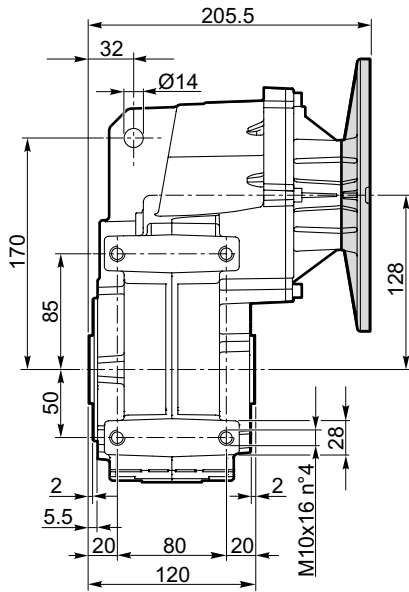

ATS 903 F..

ATSIS 903 F..

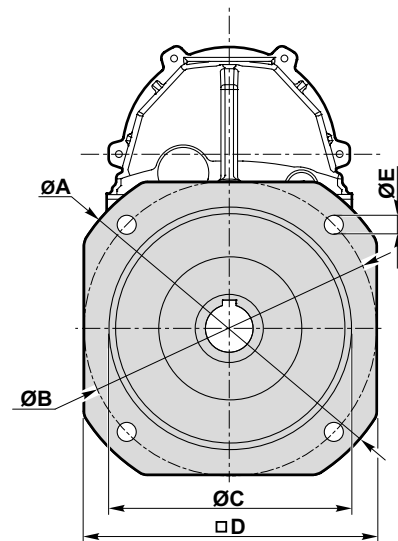
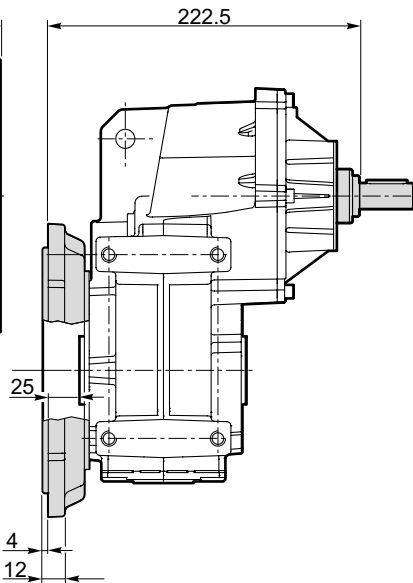
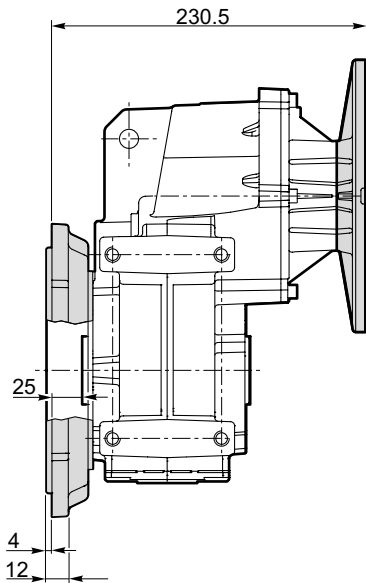

Versione F / F Version							
ATS ATSIS	ØA	ØB	ØC f7	□D	ØE	Flangia / Flange	
						Tipo / Type	Peso / Weight [kg]
903	200	165	130	165	11	F200	2
	250	215	180	215	14	F250	3.2

ATS 903.. D35 - ATSIS 903.. D35

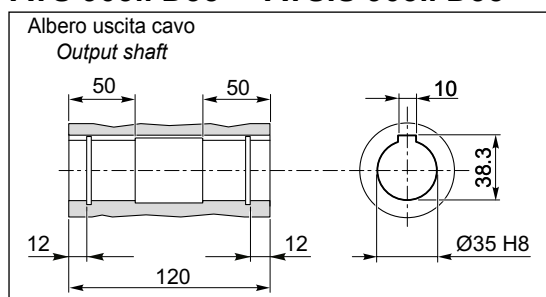

ATS

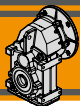

Dimensioni

Dimensions

ATS 912

ATS 912 U..

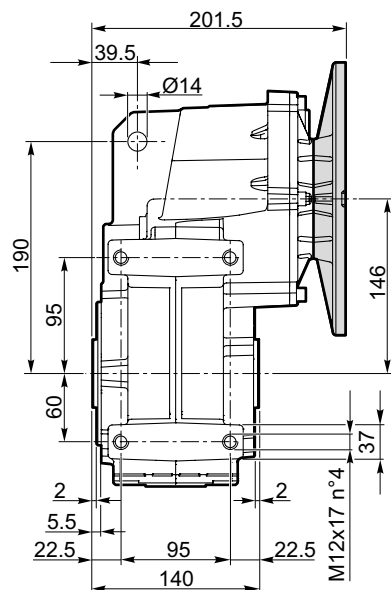

ATSIS 912 U..

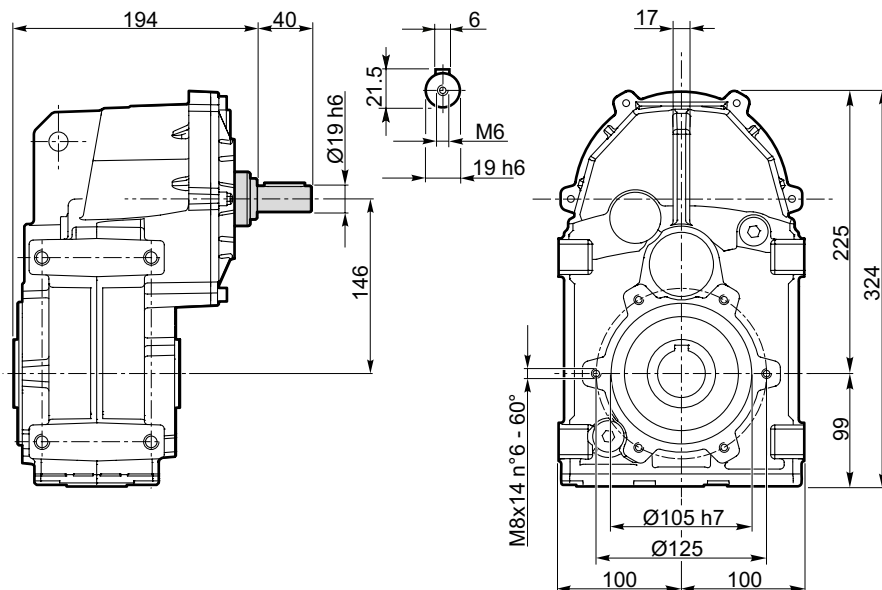

ATS 912 F..

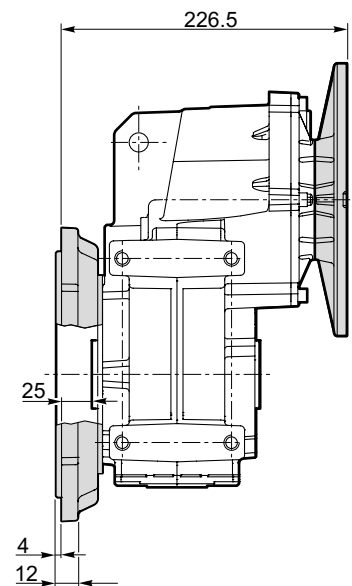

ATSIS 912 F..

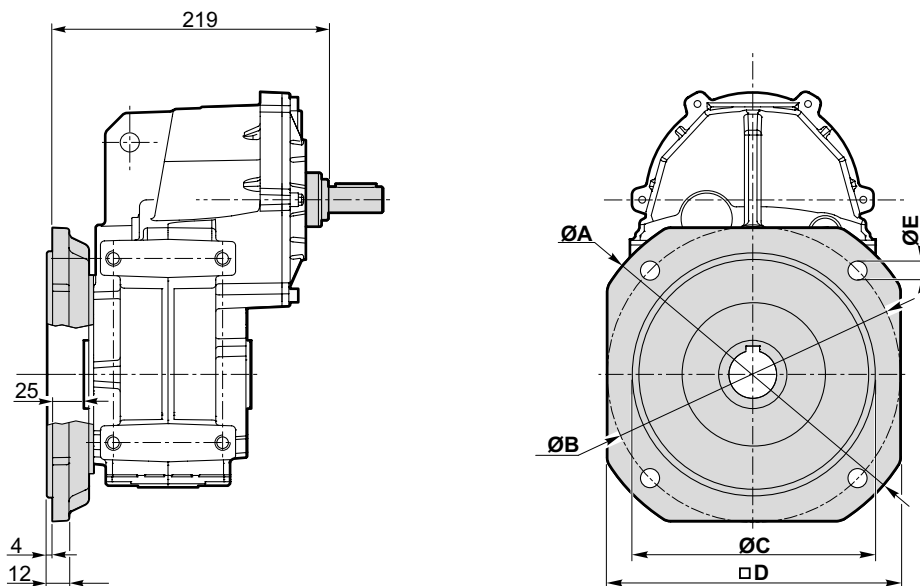

Versione F / F Version							
ATS ATSIS	ØA	ØB	ØC f7	□D	ØE	Flangia / Flange	
						Tipo / Type	Peso / Weight [kg]
912	200	165	130	165	11	F200	2
	250	215	180	215	14	F250	3.2

ATS 912.. D40 - ATSIS 912.. D40

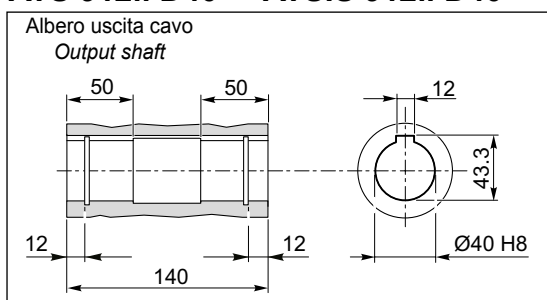

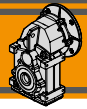

Dimensioni

Dimensions

ATS 913

ATS 913 U..

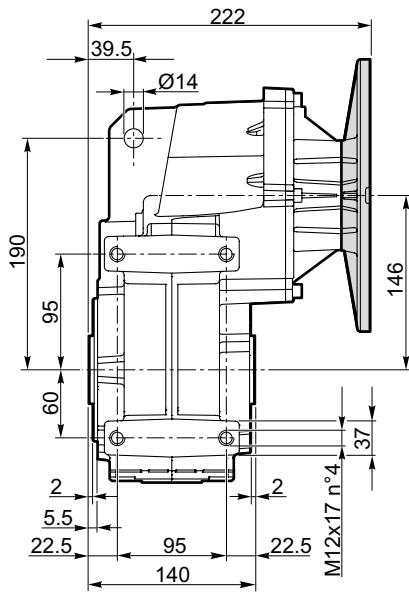

ATSIS 913 U..

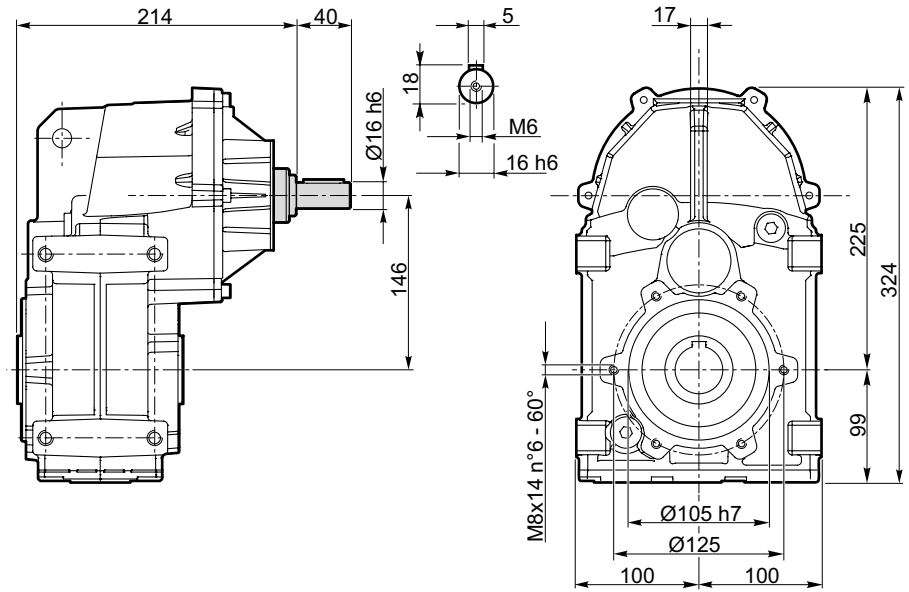

ATS 913 F..

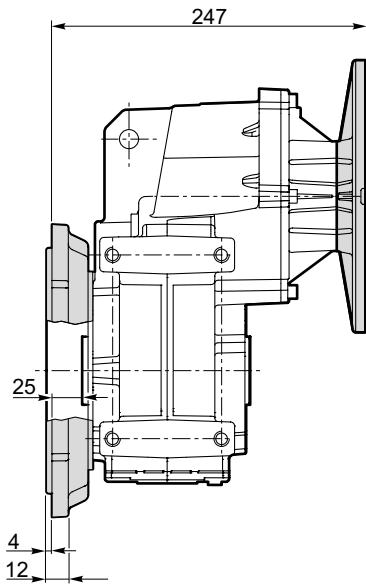

ATSIS 913 F..

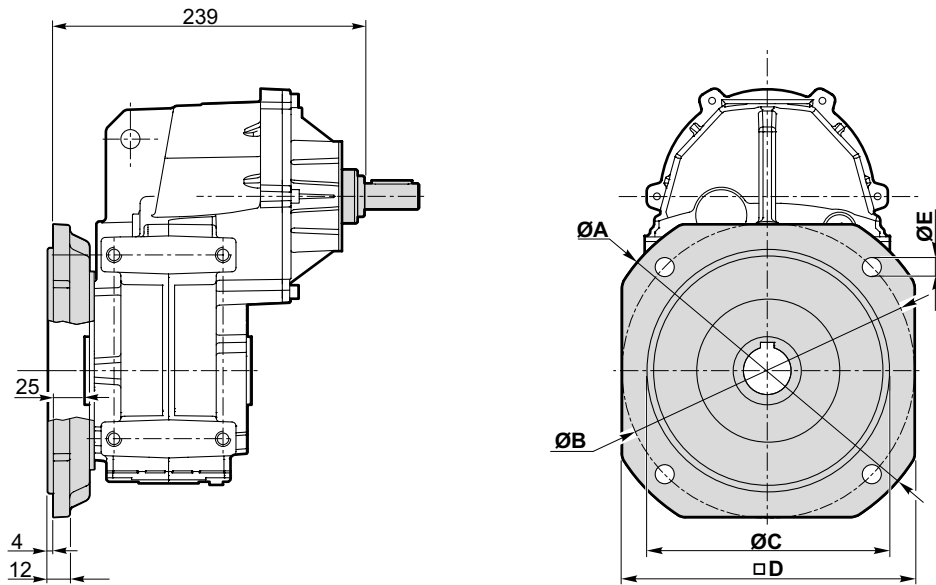

Versione F / F Version							
ATS ATSIS	ØA	ØB	ØC f7	□D	ØE	Flangia / Flange	
						Tipo / Type	Peso / Weight [kg]
913	200	165	130	165	11	F200	2
	250	215	180	215	14	F250	3.2

ATS 913.. D40 - ATSIS 913.. D40

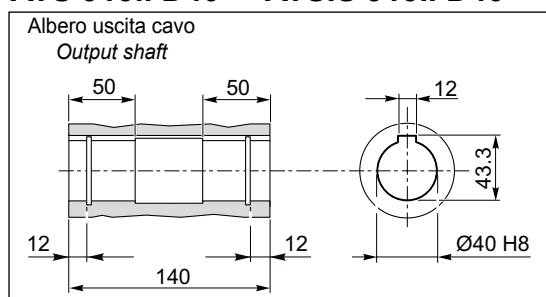

ATS

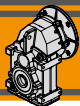

Accessori

Accessories

Albero lento semplice

Single output shaft

ATS90... U .. SZ

ATSIS90... U .. SZ

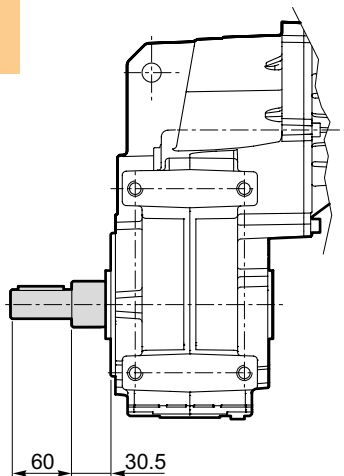
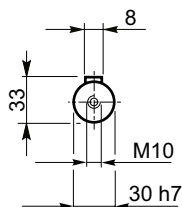

ATS90... F .. SZ

ATSIS90... F .. SZ

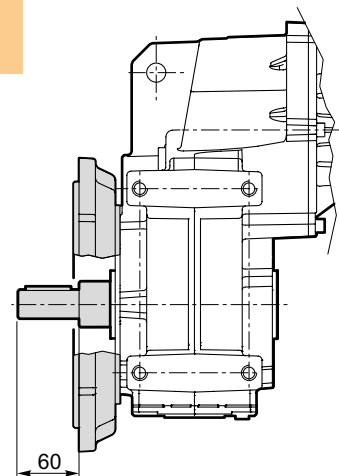
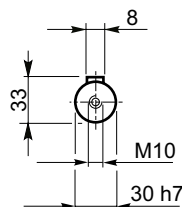

ATS91... U .. SZ

ATSIS91... U .. SZ

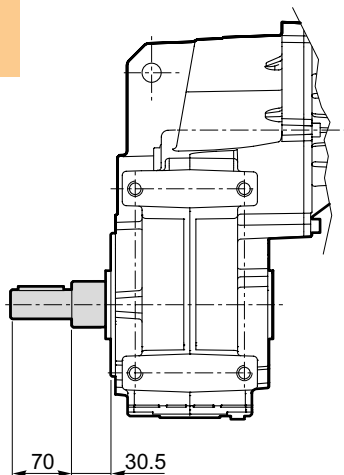
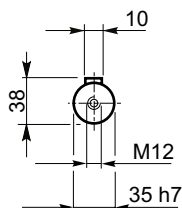

ATS91... F .. SZ

ATSIS91... F .. SZ

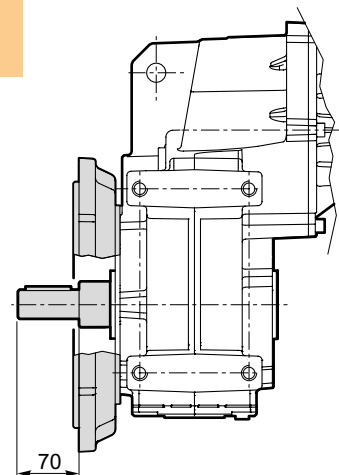
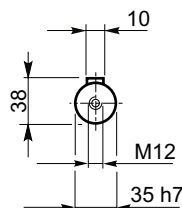

Albero lento con calettatore

Output shaft with coupling

ATS90... U .. G35

ATSIS90... U .. G35

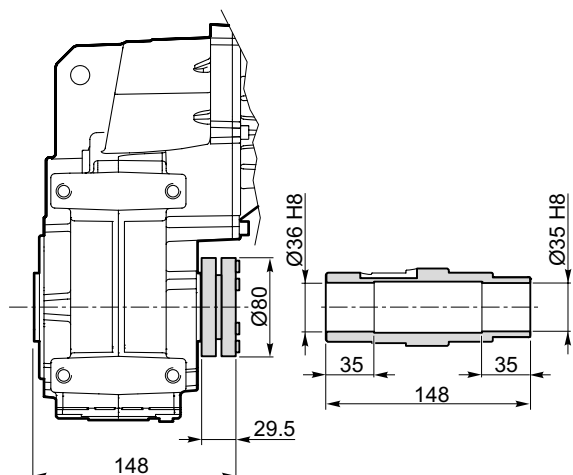

ATS91... U .. G40

ATSIS91... U .. G40

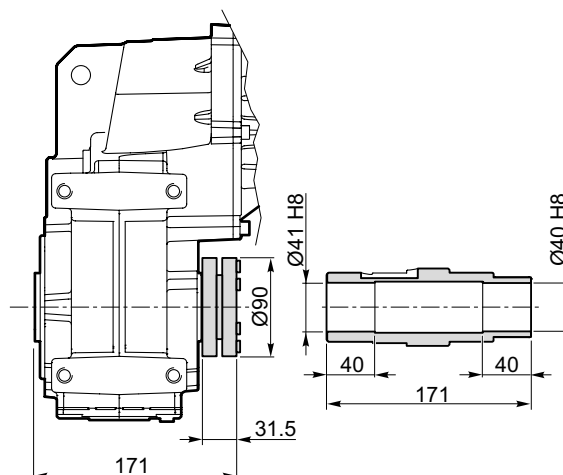

Kit albero uscita con calettatore disponibile a richiesta:
per le istruzioni di montaggio riferirsi al nostro Servizio Tecnico.

Hollow output shaft with coupling kit available upon request:
for assembly instructions please refer to our Technical Assistance

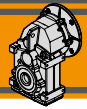

Accessori

Accessories

Kit di montaggio albero uscita

Output shaft assembly kit

ATS90...
ATS91...
ATSIS90...
ATSIS91...

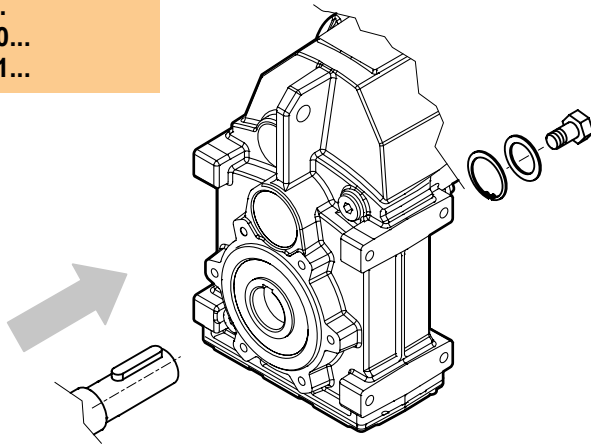

Kit di montaggio albero uscita disponibile a richiesta:
per le istruzioni di montaggio riferirsi al nostro Servizio Tecnico.

*Output shaft assembly kit available upon request:
for assembly instructions please refer to our Technical Assistance*

ATS

Kit di smontaggio albero uscita

Output shaft disassembly kit

ATS90...
ATS91...
ATSIS90...
ATSIS91...

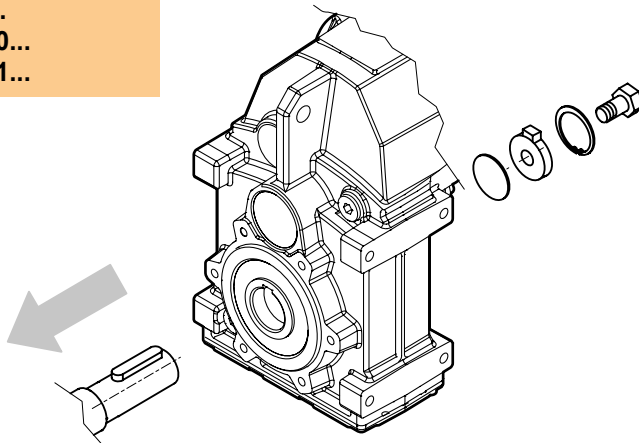

Kit di smontaggio albero uscita disponibile a richiesta:
per le istruzioni di montaggio riferirsi al nostro Servizio Tecnico.

*Output shaft disassembly kit available upon request:
for assembly instructions please refer to our Technical Assistance*

Kit braccio di reazione

Torque arm kit

ATS90...U
ATS91...U
ATSIS90...U
ATSIS91...U

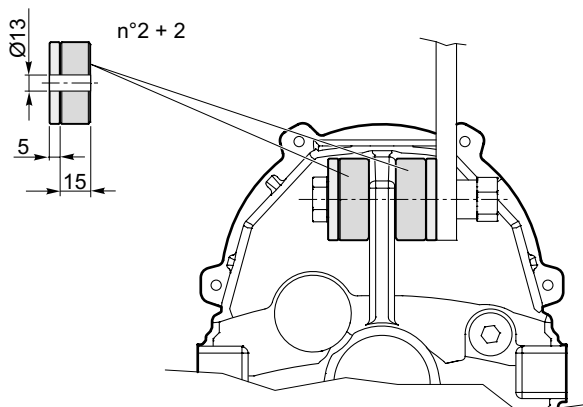

Kit braccio di reazione disponibile a richiesta:
per le istruzioni di montaggio riferirsi al nostro Servizio Tecnico.

*Torque arm kit available upon request:
for assembly instructions please refer to our Technical Assistance*



Accessori

Accessories

Coperchio di protezione

Safety cover

ATS90...

ATSIS90...

ATS91...

ATSIS91...

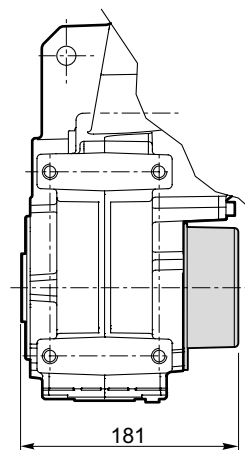
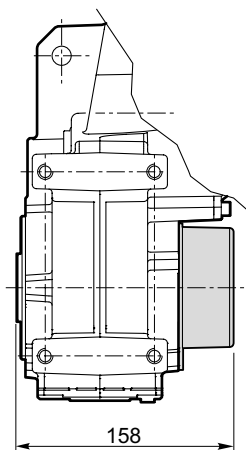
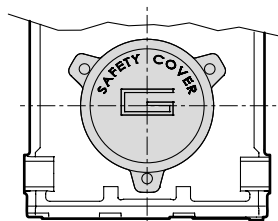

HEADQUARTERS



TRANSTECNO SRL

HEAD OFFICE

Via Caduti di Sabbiuino, 11 D/E
40011 Anzola Emilia (BO) - ITALY
Tel. +39.051.6425811
Fax +39.051.734943
sales@transtecno.com
www.transtecno.com



BRANCH

Via Ferrari, 27/11
41043 Fraz. Corlo,
Formigine (MO) - ITALY
Tel. +39.059.557522
Fax +39.059.557439
sales@transtecno.com
www.transtecno.com

MANUFACTURING PLANT



HANGZHOU TRANSTECNO POWER TRANSMISSIONS CO; LTD

Changlian Road, Fengdu industry zone,
Pingyao town Yuhang area,
Hangzhou, 311115 - CHINA
Tel. +86.571.86920260
Fax +86.571.86921810
info-china@transtecno.com
www.transtecno.cn

SUBSIDIARY



TRANSTECNO B.V.

De Stuwdam 43
ind. terrein Wieken/Vinkenhoeft
3815 KM Amersfoort
THE NETHERLANDS
Tel. +31.(0)33.4519505
Fax +31.(0)33.4519506
info@transtecno.nl
www.transtecno.nl

TRANSTECNO®
THE MODULAR GEARMOTOR

www.transtecno.com

SALES OFFICES



SALES OFFICE BRAZIL

Rua Dr. Freire Alemão 155 / 402
CEP. 90450-060
Auxiliadora Porto Alegre-RS-BRAZIL
Tel. +55.51.3251.5447
Fax +55.51.3251.5447
Mobile +55 51 811 45 962
braziloffice@transtecno.com
www.transtecno.com.br



SALES OFFICE FRANCE

12 Impasse des Mûriers
38300 Ruy - FRANCE
Tel. +33 (0) 6 85 12 09 87
Fax - Italy +39 051 733904
franceoffice@transtecno.com
www.transtecno.fr



SALES OFFICE SOUTH KOREA

D-304 Songdo BRC
Smart Valley 30,
Songdomirae-ro, Yeonsu-gu,
Incheon, 406-840, KOREA
Tel. +82 (0) 70 8288 2107
Fax. +82-32-815-2107
Mobile +82 10 5094 2107
koreaoffice@transtecno.com
www.transtecno.co.kr



SALES OFFICE INDIA

A/10, Anagha,
S.N Road, Mulund (W),
Mumbai, 400080
INDIA
Fax - Italy +39 051 733904
Mobile +91 9820614698
indiaoffice@transtecno.com



SALES OFFICE OCEANIA

Unit 11, 5-27 Wallace Ave
Point Cook 3030
Victoria - AUSTRALIA
Tel. +61.03.9369.9774
Fax +61.03.9369.9775
Mobile +61.0438.060.997
oceaniaoffice@transtecno.com
www.transtecno.com.au



SALES OFFICE EASTERN EUROPE & MIDDLE EAST

St. Magnolienweg 4
D-31860 Emmerthal - GERMANY
Tel. +49.5151.963076
Fax +49.5151.963076
Mobile +49.172.4044907
emeoffice@transtecno.com



SALES OFFICE GUANGZHOU

Room 401A, LeTian Building,
No.188 TangAn Road,
Tianhe District, Guangzhou City,
510665 - CHINA
Tel. + 86 20 38776057
Fax + 86 20 38776127
guangzhouoffice@transtecno.com