

POULTRYTECNO

The Gearmotors
for
feeding systems



TRANSTECNOTM
THE MODULAR GEARMOTOR

Riduttori monostadio PX PU
Single stage gearboxes PX PU
Einstufige Getriebe PX PU
Reductores de etapa única PX PU
Reduttore monoestàgio PX PU

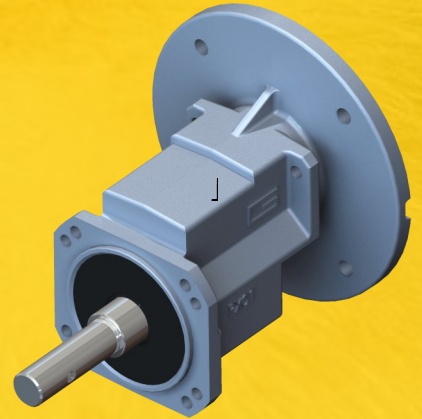

0509





Indice	Index	Inhaltsverzeichnis	Índice	Índice	Pagina Page Seite Pàgina Pagina
Descrizione	<i>Description</i>	Beschreibung	Descripción	<i>Descrição</i>	2
Designazione	<i>Classification</i>	Klassifikation	Clasificación	<i>Designação</i>	3
Lubrificazione	<i>Lubrication</i>	Schmierung	Lubricación	<i>Lubrificação</i>	3
Simbologia	<i>Symbols</i>	Symbole	Simbología	<i>Simbologia</i>	3
Dati Tecnici	<i>Technical data</i>	Technische Daten	Datos técnicos	<i>Dados Tecnicos</i>	4
Motori Applicabili	<i>IEC Motor adapters</i>	IEC Motoradapter	Motores aplicables	<i>Motores aplicáveis</i>	5
Dimensioni	<i>Dimensions</i>	Abmessungen	Dimensiones	<i>Dimensões</i>	5

Descrizione

I riduttori della gamma PoultryTecno sono stati pensati per le linee di alimentazione del settore avicolo. Sono riduttori mono-stadio con carcassa in alluminio la cui prerogativa è l'economicità, lasciando comunque libero il cliente di personalizzare flange e alberi/manicotti sia in entrata che in uscita secondo le proprie esigenze.

Description

The PoultryTecno gearbox range has been specifically designed for feeding systems in poultry farms. All gear-boxes have been made up with die-cast aluminum housing and single stage helical gears. A low cost solution with a high degree of customization. A wide selection of input/output flanges and shafts is available in order to satisfy customer specific demands.

Beschreibung

Die Getriebereihe PoultryTecno wurde speziell für Fütterungssysteme in Geflügel-farmen entwickelt. Alle Getriebe bestehen aus einem Druckguss - Aluminiumgehäuse und einstufigen Stirnrädern, also eine preisgünstige und trotzdem äußerst kundenangepasste Lösung. Eine große Auswahl an Antriebs- und Abtriebsflanschen und -wellen stehen für kundenspezifische Anforderungen zur Verfügung.

Descripción

Los reductores de la gama Poultry Tecno han sido pensados para las líneas de alimentación del sector avícola. Son reductores de etapa única con caja en aluminio, cuya dote principal es la economicidad, dejando al cliente la libertad de personalizar bridas y ejes/manguitos tanto en entrada como en salida, según sus propias necesidades .

Designação

Os redutores da gama PoultryTecno foram pensados para as linhas de alimentação do setor avicultor. São redutores mono estágio, com carcaça em alumínio, e a sua prerrogativa é a sua economia, deixando o cliente livre para personalizar flanges eixos alças, seja na entrada que na saída segundo a necessidade do cliente.

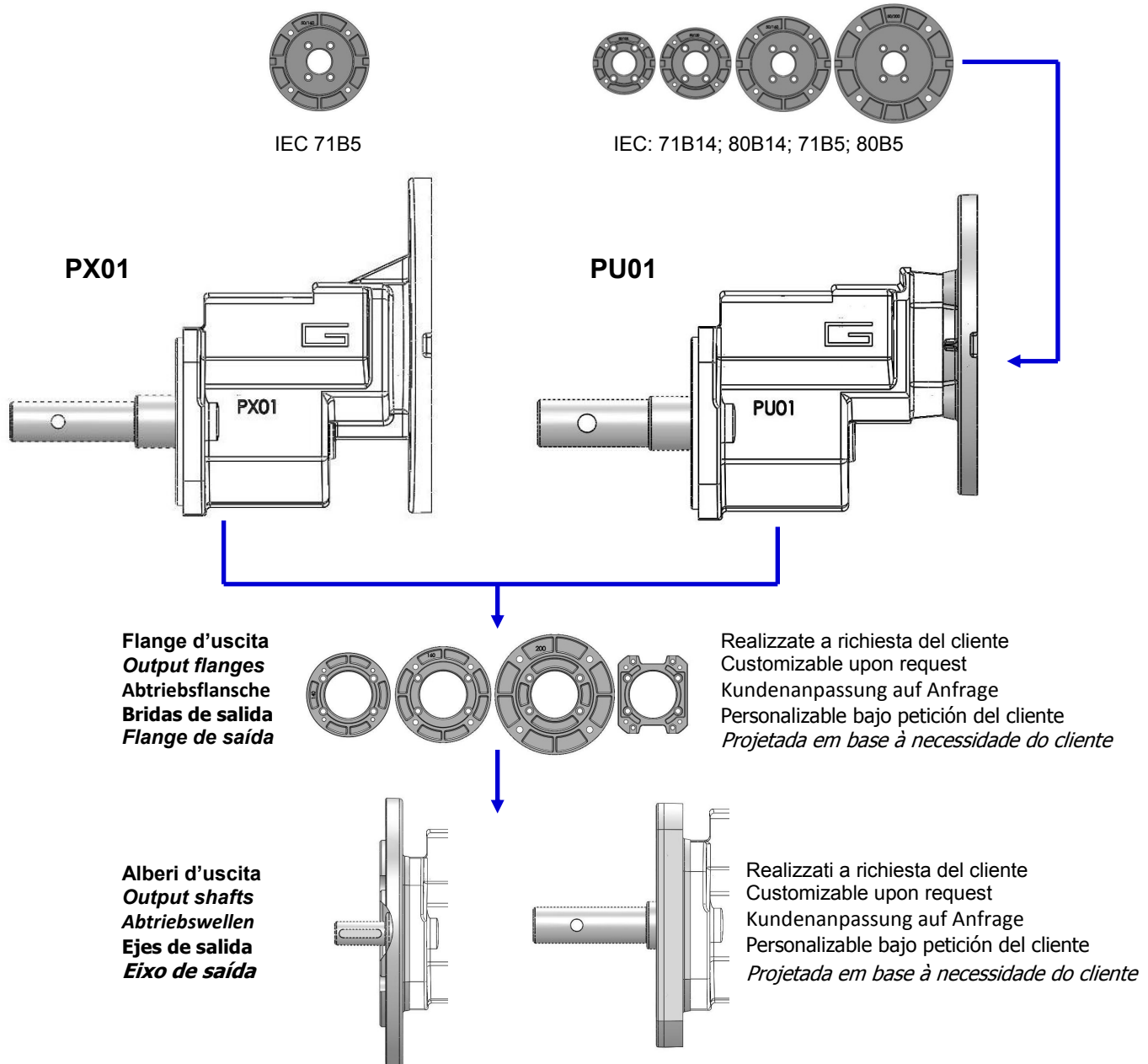
Flange d'entrata - Input flanges - Antriebsflansche - Bridas de entrada - Flange de entrada



Designazione

Classification

Klassifikation

Clasificación

Designação

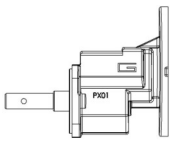

PX01 U

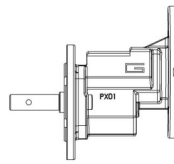

PX01 F

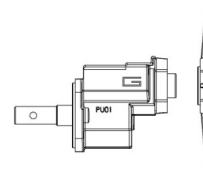

PU01 U

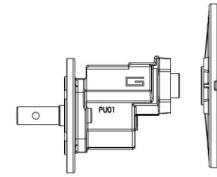

PU01 F

RIDUTTORE / GEARBOX / GETRIEBE / REDUCTOR / REDUTORE					
PU	01	3,19	FT1	P71B5	O1
Tipo Type Typ Tipo Tipo	Grandezza Size Größe Tamaño Tamanho	Rapporto Ratio Übersetzung Relación Redução	Versione Version Version Versión Versão	IEC	Albero uscita Output shaft Abtriebswelle Eje de salida Eixo de saída
PX	01	vedi tabella see tables Siehe Tabellen Vease tablas Ver tabela	U FT1 FT2 FT3 FQ1 ...	P71B5	O1 O2 O3 O4 ...
PU				P71B5 P71B14 P80B5 P80B14	

Lubrificazione

Lubrication

Schmierung

Lubricación

Dimensões

I riduttori PX e PU sono forniti completi di lubrificante sintetico viscosità 320 e non necessitano di manutenzione.

Permanent synthetic oil long-life lubrication (viscosity grade 320) on both PX and PU gearboxes.

Dauerschmierung mit Long-life Synthetiköl (Viskositätsgrad 320) für Getriebe PX und PU.

Los reductores PX y PU son provistos de lubricante sintético viscosidad 320 y no necesitan mantenimiento.

Os reductores PX e PU são fornecidos já com lubrificante sintético, com viscosidade de 320 não necessitando de manutenção .

Simbologia

Symbols

Symbole

Simbología

Simbologia

n_1 [rpm]	Velocità in ingresso	Input speed	Eingangsdrehzahl	Velocidad de entrada	Velocidade de entrada
n_2 [rpm]	Velocità in uscita	Output speed	Ausgangsdrehzahl	Velocidad de salida	Velocidade de saída
i	Rapporto di riduzione	Ratio	Übersetzung	Relación de reducción	Relação de redução
P_1 [kW]	Potenza in ingresso	Input power	Eingangsleistung	Potencia en entrada	Potência de entrada
M_n [Nm]	Coppia nominale	Nominal torque	Nennmoment	Par nominal	Torque
sf	Fattore di servizio	Service factor	Servicefaktor	Factor de servicio	Fator de serviço
R_2 [N]	Carico radiale ammissibile in uscita	Permitted output radial load	Zulässige radiale Abtriebslast	Carga radial permitida en salida	Esforço radial de saída admissível
A_2 [N]	Carico assiale ammissibile in uscita	Permitted output axial load	Zulässige axiale Abtriebslast	Carga axial permitida en salida	Esforço axial de saída admissível

Dati tecnici
Technical data
Technische Daten
Datos técnicos
Dados técnicos

P_1 [kW]	n_2 [rpm]	M_2 [Nm]	sf	i	PX - PU	IEC
0.25						
71A4 (1400rpm)	888	2,6	15,3	1,58	PX-PU01	B5/B14
	732	3,2	12,6	1,91		B5/B14
	596	3,9	10,3	2,35		B5/B14
	560	4,1	9,7	2,50		B5/B14
	467	5,0	10,1	3,00		B5/B14
	439	5,3	9,5	3,19		B5/B14
	370	6,3	8,0	3,79		B5/B14
	356	6,5	7,7	3,93		B5/B14
	295	7,9	6,4	4,75		B5/B14
	275	8,4	5,9	5,09		B5/B14
	246	9,4	5,3	5,70		B5/B14
	190	12	3,3	7,38		B5/B14
	178	13	3,1	7,88		B5/B14
163	14	2,8	8,57	B5/B14		
0.37						
71B4 (1400rpm)	888	3,9	10,4	1,58	PX-PU01	B5/B14
	732	4,7	8,5	1,91		B5/B14
	596	5,8	7,0	2,35		B5/B14
	560	6,1	6,5	2,50		B5/B14
	467	7,3	6,8	3,00		B5/B14
	439	7,8	6,4	3,19		B5/B14
	370	9,3	5,4	3,79		B5/B14
	356	10	5,2	3,93		B5/B14
	295	12	4,3	4,75		B5/B14
	275	12	4,0	5,09		B5/B14
	246	14	3,6	5,70		B5/B14
	190	18	2,2	7,38		B5/B14
	178	19	2,1	7,88		B5/B14
163	21	1,9	8,57	B5/B14		
0.55						
71C4 (1400rpm)	888	5,7	7,0	1,58	PX-PU01	B5/B14
	732	7,0	5,7	1,91		B5/B14
	596	8,6	4,7	2,35		B5/B14
	560	9,1	4,4	2,50		B5/B14
	467	11	4,6	3,00		B5/B14
	439	12	4,3	3,19		B5/B14
	370	14	3,6	3,79		B5/B14
	356	14	3,5	3,93		B5/B14
	295	17	2,9	4,75		B5/B14
	275	19	2,7	5,09		B5/B14
	246	21	2,4	5,70		B5/B14
	190	27	1,5	7,38		B5/B14
	178	29	1,4	7,88		B5/B14
163	31	1,3	8,57	B5/B14		

P_1 [kW]	n_2 [rpm]	M_2 [Nm]	sf	i	PX - PU	IEC
0.55						
80A4 (1400rpm)	888	5,7	7,0	1,58	PU01	B5/B14
	732	7,0	5,7	1,91		B5/B14
	596	8,6	4,7	2,35		B5/B14
	560	9,1	4,4	2,50		B5/B14
	467	11	4,6	3,00		B5/B14
	439	12	4,3	3,19		B5/B14
	370	14	3,6	3,79		B5/B14
	356	14	3,5	3,93		B5/B14
	295	17	2,9	4,75		B5/B14
	275	19	2,7	5,09		B5/B14
	246	21	2,4	5,70		B5/B14
	190	27	1,5	7,38		B5/B14
	178	29	1,4	7,88		B5/B14
163	31	1,3	8,57	B5/B14		
0.75						
80B4 (1400rpm)	888	7,8	5,1	1,58	PU01	B5/B14
	732	9,5	4,2	1,91		B5/B14
	596	12	3,4	2,35		B5/B14
	560	12	3,2	2,50		B5/B14
	467	15	3,4	3,00		B5/B14
	439	16	3,2	3,19		B5/B14
	370	19	2,7	3,79		B5/B14
	356	19	2,6	3,93		B5/B14
	295	24	2,1	4,75		B5/B14
	275	25	2,0	5,09		B5/B14
	246	28	1,8	5,70		B5/B14
	190	37	1,1	7,38		B5/B14
	178	39	1,0	7,88		B5/B14
1.1						
80C4 (1400rpm)	888	11	3,5	1,58	PU01	B5/B14
	732	14	2,9	1,91		B5/B14
	596	17	2,3	2,35		B5/B14
	560	18	2,2	2,50		B5/B14
	467	22	2,3	3,00		B5/B14
	439	23	2,2	3,19		B5/B14
	370	28	1,8	3,79		B5/B14
	356	29	1,7	3,93		B5/B14
	295	35	1,4	4,75		B5/B14

Rapporti preferenziali
Preferred ratios
Vorzugsübersetzungen
Relaciones de reducción preferenciales
Relações preferenciais



Motori applicabili

IEC Motor adapters

IEC Motoradapter

Motores aplicables

Motores aplicáveis

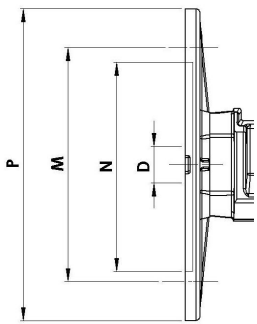

	IEC	N	M	P	D	Rapporti / Ratios / Übersetzung / Relación / Redução											
						1,58	1,91	2,35	2,50	3,00	3,19	3,79	3,93	4,75	5,09	5,70	7,38
PX	71B5	110	130	160	14	B											
PU	80B5	130	165	200	19												
	80B14	80	100	120	14												
	71B5	110	130	160													
	71B14	70	85	105													

N.B. Le aree in grigio indicano l'applicabilità delle corrispondenti grandezze motore; **B** = Boccola di riduzione in acciaio

N.B. Grey areas indicate motor inputs available on each size of unit; **B** = Metal shaft sleeve

N.B. In den grauen Bereichen sind die Motoreingänge für jede Getriebegröße angegeben; **B** = Metal-Wellenhülse

N.B. Las áreas en gris indican la disponibilidad del correspondiente tamaño del motor; **B** = casquillo de reducción en acero

Obs. As áreas em cinza indicam a aplicabilidade dos correspondentes tamanhos de motores; **B** = bucha de redução em aço

Dimensioni

Dimensions

Abmessungen

Dimensiones

Dimensões

PX01 U - PU01 U

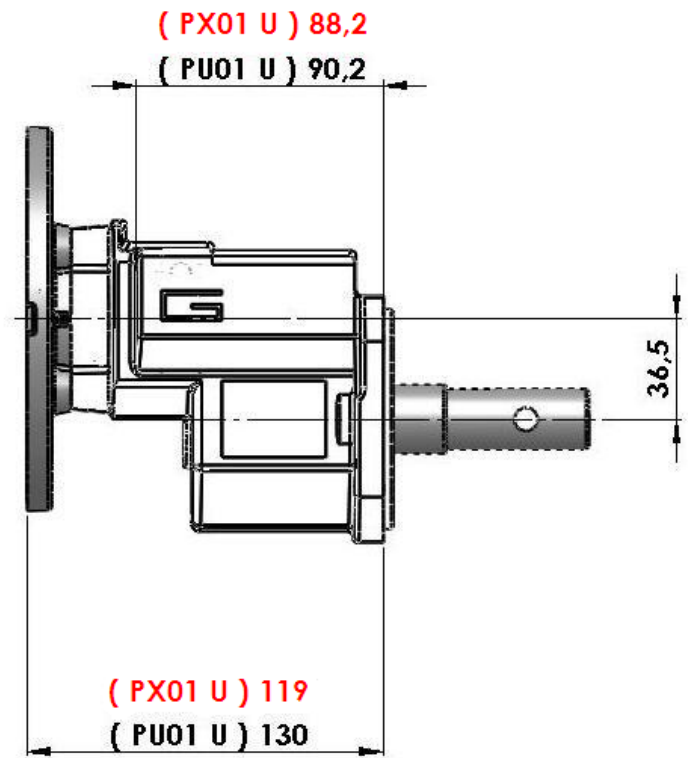
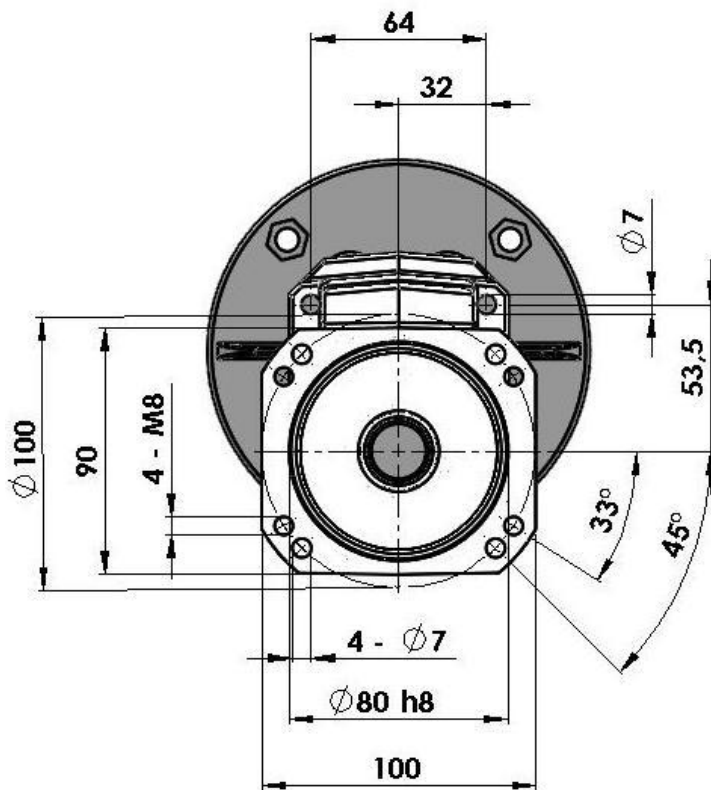

IMPORTANT !

Nota: Per la scelta delle flange e degli alberi in uscita preghiamo di riferirsi alla pagina seguente. Se non sono presenti i componenti desiderati ricordiamo che è possibile personalizzarli secondo le Vostre specifiche.

Note: Please see the following page for the output shafts and flanges available. If you can't find the right components we can customize them upon request.

Anmerkung: Abtriebswellen und -flansche siehe nächste Seite. Wenn die passende Komponente nicht aufgeführt ist, ist eine Kundenanpassung auf Anfrage möglich.

Nota: Para elegir bridas y ejes de salida rogamos hagan referencia a la página siguiente. Si los componentes que desean no están presentes, recordamos que es posible personalizarlos según sus necesidades.

Nota: Para a escolha das flanges e dos eixos de saída pedimos de seguir a próxima página. Se não estão presentes os componentes necessitados lembramos que é possível personalizar-los de acordo com as vossas especificações.

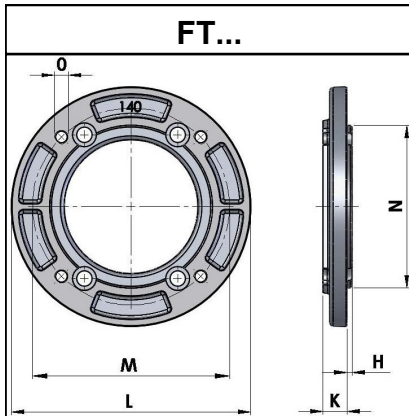
Dimensioni
Dimensions
Abmessungen
Dimensiones
Dimensões
Flange d'uscita / Output flange / Abtriebsflansche / Bridas de salida / Flange de saída

FT	Dimensioni / Dimensions / Abmessungen / Dimensiones / Dimensões					
	H	K	L	M	N	O
1	3	14	140	115	95	M8
2	3,5	14	160	130	110	M8
3	3,5	14	200	165	130	11
...

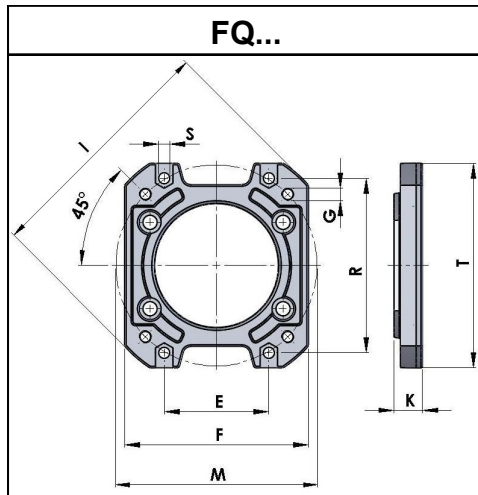

FQ	Dimensioni / Dimensions / Abmessungen / Dimensiones / Dimensões								
	E	F	G	I	K	M	R	S	T
1	66	116	M8	154	18	127	110	7	129
...

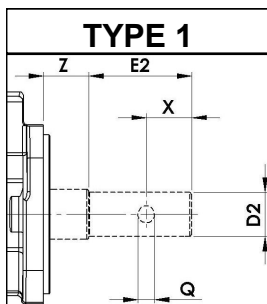
Alberi d'uscita / Output shafts / Abtriebswellen / Ejes de salida / Eixo de saída

PX01 U/F PU01 U/F	Dimensioni / Dimensions / Abmessungen / Dimensiones / Dimensões				
	D2	E2	X	Z	Q
O1	22	52	23	23	8,5
O4	19	60	23	23	6,5
...

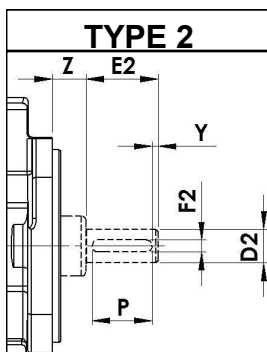

PX01 U/F PU01 U/F	Dimensioni / Dimensions / Abmessungen / Dimensiones / Dimensões					
	D2	E2	Y	F2	P	Z
O2	14	30	2,5	5	25	14
O3	19	40	3	6	30	0
...



TRANSTECNO™

THE MODULAR GEARMOTOR

HEADQUARTER



TRANSTECNO SRL
Via Caduti di Sabbiuno, 11 D/E
40011 Anzola Emilia (BO) ITALY
Tel. +39.051.6425811
Fax +39.051.734943
info@transtecno.com
www.transtecno.com

MANUFACTURING PLANT



HANGZHOU TRANSTECNO
POWER TRANSMISSIONS CO; LTD
26, No.1 Street
Hangzhou Economic & Technological
Development Area
Hangzhou, CHINA
Tel. +86.571.86921603
Fax +86.571.86921810
info-china@transtecno.com
www.transtecno.cn

SALES OFFICES & WAREHOUSES



GEARTECNO ITALIA SRL
Via Ferrari, 27/11
41043 Fraz. Corlo, Formigine (MO)
ITALY
Tel. +39.059.557522
Fax +39.059.557439
info@geartecno.com
www.geartecno.com



GEARTECNO HOLLAND B.V.
De Stuwdam 43
ind. terrein Wieken/Vinkenhoeft
3815 KM Amersfoort
THE NETHERLANDS
Tel. +31.(0)33.4519505
Fax +31.(0)33.4519506
info@geartecno.nl
www.geartecno.nl

SALES OFFICES



GERMAN SALES OFFICE
Schonebeck 99
D-48329 Havixbeck
GERMANY
Tel. +49-(0)2534-644425
Mobile +49-(0)179-1298682
Fax +49-(0)2534-645875
germanoffice@transtecno.com



SALES OFFICE BRAZIL
Rua Vicente da Fontoura, 2547/404
CEP. 90640-003
PORTO ALEGRE -RS -BRASIL
Tel. +55-51-3251-5447
Fax +55-51-3251-5447
braziloffice@transtecno.com
www.transtecno.com.br