

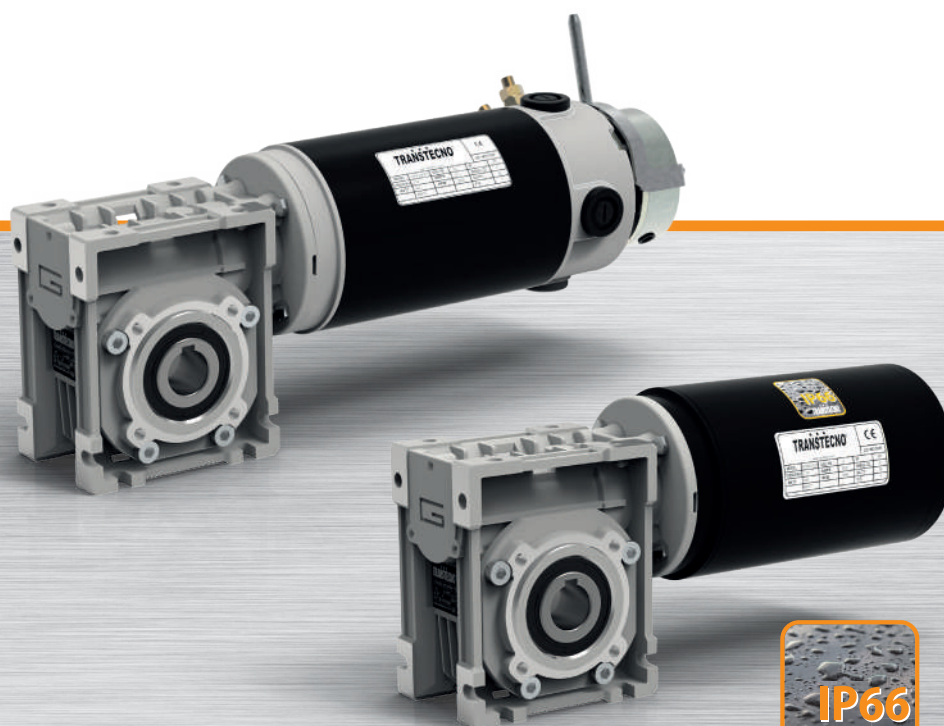

Ferrite

Motoriduttori CC a vite senza fine  
**DC wormgearmotors**





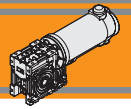

<b>Indice</b>	<b>Index</b>	Pag. Page
Caratteristiche tecniche	<i>Technical features</i>	<b>02</b>
Designazione	<i>Classification</i>	<b>02</b>
Simbologia	<i>Symbols</i>	<b>02</b>
Lubrificazione	<i>Lubrication</i>	<b>03</b>
Carichi radiali	<i>Radial loads</i>	<b>03</b>
Dati di dentatura	<i>Toothing data</i>	<b>04</b>
Rendimento	<i>Efficiency</i>	<b>04</b>
Dati tecnici per servizio S2	<i>Technical data for S2 duty</i>	<b>05</b>
Motori applicabili	<i>Motor adapters</i>	<b>06</b>
Dimensioni	<i>Dimensions</i>	<b>07</b>
Opzioni	<i>Options</i>	<b>020</b>
Accessori	<i>Accessories</i>	<b>021</b>

Questa sezione annulla e sostituisce ogni precedente edizione o revisione. Qualora questa sezione non Vi sia giunta in distribuzione controllata, l'aggiornamento dei dati ivi contenuto non è assicurato. **In tal caso la versione più aggiornata è disponibile sul nostro sito internet [www.transtecno.com](http://www.transtecno.com)**

*This section replaces any previous edition and revision. If you obtained this catalogue other than through controlled distribution channels, the most up to date content is not guaranteed. In this case the latest version is available on our web site [www.transtecno.com](http://www.transtecno.com)*

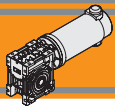

**Caratteristiche tecniche**

**Technical features**

Le caratteristiche principali dei motoriduttori CC a vite senza fine a magneti permanenti in ferrite serie ECM sono:

The main features of ECM ferrite permanent magnets DC wormgearmotors range are:

- Alimentazione in bassa tensione 12/24 Vcc
- Possibilità di montaggio encoder
- Potenze motore disponibili da 100 a 800W S2
- Magneti in ferrite
- Carcasse dei riduttori in pressofusione di alluminio
- Lubrificazione permanente con olio sintetico.

- Low voltage power supply 12/24 Vdc
- Suitable for encoder assembly
- Motor power ratings available from 100 to 800W S2
- Ferrite magnets
- Die-cast aluminum housing
- Permanent synthetic oil long-life lubrication.

**Designazione**

**Classification**

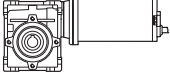
MOTORIDUTTORE / GEARMOTOR													
ECM	070/026						U	10	SZDX	BRSX	90	240	VS
Tipo Type	Grandezza Size						Versione Riduttore Gearbox Version	Rapporto Ratio	Albero di uscita Output shaft	Braccio di reazione Torque arm	Angolo Angle	Versione Motore Motor Version	Opzioni Options
	070/026	100/026	180/026	250/030	350/030	600/040	U F...	Vedere tabella See tables	SZDX SZSX DZ	BRDX BRSX	0° 90° 180° 270°	120 240 24E	VS
	070/026 (D11) 070/026 (D14) 070/030	100/0026 (D11) 100/026 (D14) 100/030 100/040	180/026 (D11) 180/026 (D14) 180/030 180/040 180/050	250/040	350/040	600/050 600/063 600/070							

Versione Riduttore  
Gearbox Version

Albero di uscita  
Output shaft

Braccio di reazione  
Torque arm \*

Angolo  
Angle

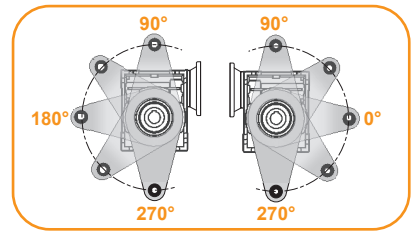
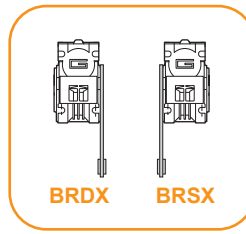
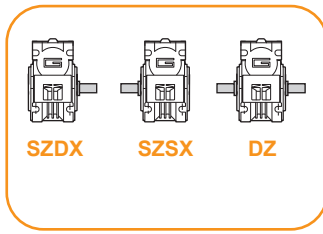
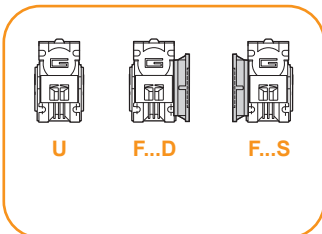

\* NOTA: il braccio di reazione viene fornito smontato.  
NOTE: the torque arm will be supplied not assembled.

**Simbologia**

**Symbols**

$n_1$ [min <sup>-1</sup> ]	Velocità in ingresso / Input speed	$R_d$ %	Rendimento dinamico / Dynamic efficiency
$n_2$ [min <sup>-1</sup> ]	Velocità in uscita / Output speed	$A_2$ [N]	Carico assiale ammissibile in uscita / Permitted output axial load
$i$	Rapporto di riduzione / Ratio	$R_s$ %	Rendimento statico / Static efficiency
$P_1$ [kW]	Potenza in entrata / Input power	$R_2$ [N]	Carico radiale ammissibile in uscita / Permitted output radial load
$M_2$ [Nm]	Coppia in uscita in funzione di $P_1$ / Output torque referred to $P_1$	$Z$	Numero di principi della vite / Worm starts
$sf$	Fattore di servizio / Service factor	$\beta$	Angolo d'elica / Helix angle



**Lubrificazione**

**Lubrication**

I riduttori a vite senza fine della serie CM sono lubrificati a vita con olio sintetico di viscosità 320 e possono essere installati in qualunque posizione di montaggio.

Permanent synthetic oil long-life lubrication allow to use CM wormgearbox range in all mounting position.

**Carichi radiali**

**Radial loads**

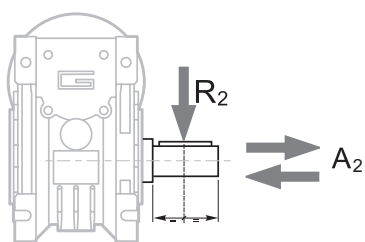

$A_2 = R_2 \times 0.2$

n <sub>2</sub> [min <sup>-1</sup> ]	R <sub>2</sub> [N]					
	CM026	CM030	CM040	CM050	CM063	CM070
600	271	457	857	1200	1657	-
400	310	523	981	1374	1897	2028
300	342	576	1080	1512	2088	2232
200	391	659	1236	1731	2390	2555
150	479	726	1361	1905	2631	2812
120	514	782	1466	2052	2834	3030
100	547	831	1558	2181	3012	3219
75	609	914	1715	2400	3315	3543
60	610	985	1847	2586	3571	3817
50	-	1047	1963	2748	3794	4056
38	-	1147	2151	3011	4158	4445
30	-	1241	2327	3258	4499	4809

Quando il carico radiale risultante non è applicato sulla mezzeria dell'albero occorre calcolare quello effettivo con la seguente formula:

When the resulting radial load is not applied on the centre line of the shaft it is necessary to calculate the effective load with the following formula:

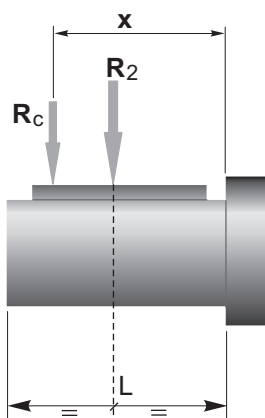

$$R_c = \frac{R_2 \cdot a}{(b + x)} \leq R_{2MAX}$$

$$R \leq R_c$$

a, b = valori riportati nella tabella  
a, b = values given in the table

	CM					
	026	030	040	050	063	070
a	56	65	84	101	120	122
b	43	50	64	76	95	92
R <sub>2MAX</sub>	610	1600	3000	4200	5800	6200

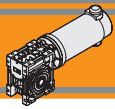

**Dati di dentatura**

**Toothing data**

	Dati della coppia vite-corona Worm wheel data	Rapporto / Ratio											
		5	7.5	10	15	20	25	30	40	50	60	80	100
CM026	Z	6	4	3	2	2		1	1	1	1		
	$\beta$	34° 35'	24° 41'	19° 1'	12° 57'	10° 30'		6° 33'	5° 17'	4° 26'	3° 49'		
CM030	Z	6	4	3	2	2	2	1	1	1	1	1	1
	$\beta$	27° 4'	24° 28'	18° 50'	12° 49'	10° 23'	8° 43'	6° 29'	5° 14'	4° 23'	3° 46'	2° 57'	2° 25'
CM040	Z	6	4	3	2	2	2	1	1	1	1	1	1
	$\beta$	34° 19'	24° 28'	18° 50'	12° 49'	10° 23'	8° 43'	6° 29'	5° 14'	4° 23'	3° 46'	2° 57'	2° 25'
CM050	Z	6	4	3	2	2	2	1	1	1	1	1	1
	$\beta$	33° 37'	23° 54'	18° 23'	12° 29'	10° 6'	8° 28'	6° 19'	5° 5'	4° 15'	3° 39'	2° 51'	2° 20'
CM063	Z	6	4	3	2	2	2	1	1	1	1	1	1
	$\beta$	34° 23'	24° 31'	18° 53'	12° 50'	10° 24'	8° 44'	6° 30'	5° 14'	4° 23'	3° 47'	2° 57'	2° 25'
CM070	Z		4	3	2	2	2	1	1	1	1	1	1
	$\beta$		26° 12'	20° 15'	13° 49'	11° 15'	9° 29'	7° 0'	5° 41'	4° 46'	4° 7'	3° 13'	2° 39'

**Rendimento**

**Efficiency**

	$n_1$ [min <sup>-1</sup> ]	Rendimento Efficiency	Rapporto / Ratio											
			5	7.5	10	15	20	25	30	40	50	60	80	100
CM026	2800	Rd	89	87	85	83	80		73	68	64	60		
	1400		87	84	83	78	74		66	61	57	53		
	900		84	83	80	75	71		61	57	52	48		
			Rs	72	71	68	61	56		46	41	36	34	
CM030	2800	Rd	89	88	86	84	81	78	74	70	65	62	57	52
	1400		86	85	84	79	75	72	67	62	58	55	48	43
	900		84	83	81	75	71	68	62	58	53	49	43	39
			Rs	72	67	63	55	50	43	39	35	31	27	23
CM040	2800	Rd	90	89	87	84	83	80	77	73	69	66	60	56
	1400		88	86	84	81	78	74	70	65	60	58	52	46
	900		86	84	82	77	74	70	66	60	57	53	46	41
			Rs	74	71	67	60	55	51	45	40	36	32	28
CM050	2800	Rd	91	90	88	86	84	82	78	74	71	68	62	58
	1400		89	87	85	82	79	76	72	67	63	60	54	49
	900		87	85	84	79	75	72	68	62	59	55	48	43
			Rs	73	70	66	59	55	51	44	39	35	32	27
CM063	2800	Rd	91	90	88	86	84	83	79	76	73	70	65	60
	1400		90	88	86	84	81	78	75	70	66	63	57	52
	900		89	86	84	81	78	75	70	65	61	58	52	47
			Rs	73	71	67	60	55	51	45	40	36	33	28
CM070	2800	Rd		90	89	87	85	84	80	77	74	72	67	62
	1400			89	87	84	82	80	76	72	68	65	60	53
	900			87	85	82	79	77	72	67	63	60	54	49
			Rs		72	69	62	60	55	48	43	38	36	31



**Rendimento teorico del riduttore dopo il rodaggio**  
*Theoretical efficiency of the gearbox after the first running period*





Dati tecnici per servizio S2

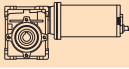
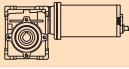
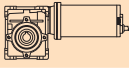
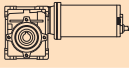

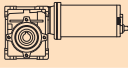
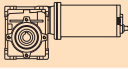
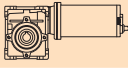
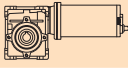
Technical data for S2 duty

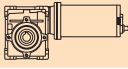
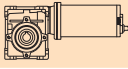
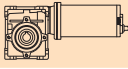
P <sub>1</sub> [W]	n <sub>2</sub> [min <sup>-1</sup> ]	M <sub>2</sub> [Nm]	sf	i		Versione motore Motor version	
<b>100</b>							
(3000 min <sup>-1</sup> )	<b>600</b>	1.4	7.1	5		ECM070/026 12E/24E	
	<b>400</b>	2.1	5.3	7.5		120.66/240.66	
	<b>300</b>	2.7	4.1	10			
	<b>200</b>	4.0	2.8	15			
	<b>150</b>	5.1	2.2	20			
	<b>100</b>	7.0	1.7	30			
	<b>75</b>	8.7	1.3	40			
	<b>60</b>	10	1.0	50			
	<b>50</b>	11	0.8	60			
	<b>150</b>	5.2	2.7	20			ECM070/030 12E/24E
	<b>120</b>	6.2	2.4	25	120.66/240.66		
	<b>100</b>	7.1	2.5	30			
	<b>75</b>	8.9	1.8	40			
	<b>60</b>	10	1.4	50			
	<b>50</b>	12	1.2	60			
	<b>38</b>	15	0.8	80			
	<b>30</b>	17	0.7	100			
	<b>50</b>	13	2.3	60			ECM070/040 12E/24E
	<b>38</b>	15	1.8	80			120.66/240.66
	<b>30</b>	18	1.4	100			

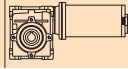
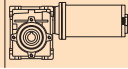
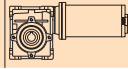
P <sub>1</sub> [W]	n <sub>2</sub> [min <sup>-1</sup> ]	M <sub>2</sub> [Nm]	sf	i		Versione motore Motor version
<b>140</b>						
(3000 min <sup>-1</sup> )	<b>600</b>	2.0	5.0	5		ECM100/026 120/240/24E
	<b>400</b>	2.9	3.8	7.5		120.66/240.66
	<b>300</b>	3.8	2.9	10		
	<b>200</b>	5.5	2.0	15		
	<b>150</b>	7.1	1.5	20		
	<b>100</b>	10	1.2	30		
	<b>75</b>	12	0.9	40		
	<b>60</b>	14	0.7	50		
	<b>50</b>	13	0.7	60		
	<b>200</b>	5.6	2.8	15		
	<b>150</b>	7.2	1.9	20	120.66/240.66	
	<b>120</b>	8.7	1.7	25		
	<b>100</b>	10	1.8	30		
	<b>75</b>	12	1.3	40		
	<b>60</b>	14	1.0	50		
	<b>50</b>	17	0.8	60		
	<b>38</b>	17	0.7	80		
	<b>30</b>	16	0.7	100		
	<b>100</b>	10	3.7	30		
	<b>75</b>	13	2.6	40		24E
	<b>60</b>	15	2.1	50		120.66/240.66
	<b>50</b>	18	1.6	60		
	<b>38</b>	21	1.3	80		
	<b>30</b>	25	1.0	100		

P <sub>1</sub> [W]	n <sub>2</sub> [min <sup>-1</sup> ]	M <sub>2</sub> [Nm]	sf	i		Versione motore Motor version
<b>250</b>						
(3000 min <sup>-1</sup> )	<b>600</b>	3.5	2.8	5		ECM180/026 120/240
	<b>400</b>	5.2	2.1	7.5		120.66/240.66
	<b>300</b>	6.8	1.6	10		
	<b>200</b>	10	1.1	15		
	<b>150</b>	13	0.9	20		
	<b>100</b>	17	0.7	30		
	<b>75</b>	16	0.7	40		
	<b>60</b>	14	0.7	50		
	<b>50</b>	13	0.7	60		
	<b>600</b>	3.5	3.7	5		
	<b>400</b>	5.3	2.9	7.5	120.66/240.66	
	<b>300</b>	6.8	2.3	10		
	<b>200</b>	10	1.6	15		
	<b>150</b>	13	1.1	20		
	<b>120</b>	16	1.0	25		
	<b>100</b>	18	1.0	30		
	<b>75</b>	22	0.7	40		
	<b>60</b>	21	0.7	50		
	<b>50</b>	20	0.7	60		
	<b>38</b>	17	0.7	80		
	<b>30</b>	16	0.7	100		
						120/240
						120.66/240.66

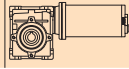
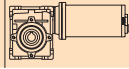
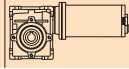
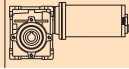
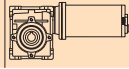
P <sub>1</sub> [W]	n <sub>2</sub> [min <sup>-1</sup> ]	M <sub>2</sub> [Nm]	sf	i		Versione motore Motor version
<b>250</b>						
(3000 min <sup>-1</sup> )	<b>200</b>	10	3.5	15		ECM180/040 120/240*
	<b>150</b>	13	2.3	20		24E
	<b>120</b>	16	1.8	25		120.66/240.66
	<b>100</b>	18	2.1	30		
	<b>75</b>	23	1.5	40		
	<b>60</b>	27	1.2	50		
	<b>50</b>	32	0.9	60		
	<b>38</b>	38	0.7	80		
	<b>30</b>	34	0.7	100		
	<b>75</b>	24	2.5	40		
	<b>60</b>	28	2.0	50	IEC 63B14	
	<b>50</b>	32	1.6	60		
	<b>38</b>	39	1.2	80	Solo / Only	
	<b>30</b>	46	0.9	100		

P <sub>1</sub> [W]	n <sub>2</sub> [min <sup>-1</sup> ]	M <sub>2</sub> [Nm]	sf	i		Versione motore Motor version
<b>350</b>						
(3000 min <sup>-1</sup> )	<b>600</b>	5.0	2.6	5		ECM250/030 120/240
	<b>400</b>	7.4	2.0	7.5		120.66/240.66
	<b>300</b>	10	1.7	10		
	<b>200</b>	14	1.1	15		
	<b>150</b>	18	0.8	20		
	<b>120</b>	22	0.7	25		
	<b>100</b>	25	0.7	30		
	<b>75</b>	22	0.7	40		
	<b>60</b>	21	0.7	50		
	<b>200</b>	14	2.5	15		
	<b>150</b>	18	1.7	20	120.66/240.66	
	<b>120</b>	22	1.3	25		
	<b>100</b>	26	1.5	30		
	<b>75</b>	33	1.0	40		
	<b>60</b>	38	0.8	50		
	<b>50</b>	44	0.7	60		
	<b>38</b>	38	0.7	80		
	<b>30</b>	35	0.7	100		
	<b>150</b>	19	2.9	20		
	<b>120</b>	23	2.2	25		120.66/240.66
	<b>100</b>	26	2.6	30		
	<b>75</b>	33	1.8	40		
	<b>60</b>	40	1.4	50		
	<b>50</b>	45	1.1	60		
	<b>38</b>	55	0.8	80		
	<b>30</b>	65	0.7	100		
	<b>75</b>	34	3.3	40		ECM250/063 120/240
	<b>60</b>	41	2.5	50		IEC 71B14
	<b>50</b>	47	2.1	60		
	<b>38</b>	58	1.5	80		Solo / Only
	<b>30</b>	67	1.2	100		

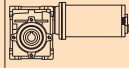
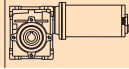
P <sub>1</sub> [W]	n <sub>2</sub> [min <sup>-1</sup> ]	M <sub>2</sub> [Nm]	sf	i		Versione motore Motor version
<b>500</b>						
(3000 min <sup>-1</sup> )	<b>600</b>	7.1	1.8	5		ECM350/030 120/240
	<b>400</b>	11	1.4	7.5		120.66/240.66
	<b>300</b>	14	1.2	10		
	<b>200</b>	20	0.8	15		
	<b>150</b>	20	0.7	20		
	<b>120</b>	21	0.7	25		
	<b>100</b>	26	0.7	30		
	<b>75</b>	23	0.7	40		
	<b>60</b>	21	0.7	50		

N.B.  
Verificare sempre che la coppia M<sub>2</sub> utilizzata non ecceda il valore indicato nelle caselle in grigio  
N.B.  
Please check that the output torque M<sub>2</sub> does not exceed the value in the grey areas

NOTA: per servizio continuo o altamente intermittente, contattare il servizio tecnico

NOTE: for continuous or highly intermittent duty, please contact our technical service

\*: Motore inclinato con portaspazzole a 45°  
Motor assembly with brush holder inclined 45°

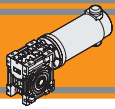

**Dati tecnici per servizio S2**

**Technical data for S2 duty**

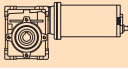
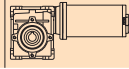
P <sub>1</sub> [W]	n <sub>2</sub> [min <sup>-1</sup> ]	M <sub>2</sub> [Nm]	sf	i		Versione motore Motor version	P <sub>1</sub> [W]	n <sub>2</sub> [min <sup>-1</sup> ]	M <sub>2</sub> [Nm]	sf	i		Versione motore Motor version	
<b>500</b>							<b>800</b>							
(3000 min <sup>-1</sup> )	<b>600</b>	7.2	4.0	5	<b>ECM350/040</b>	120/240	(3000 min <sup>-1</sup> )	<b>600</b>	11	2.5	5	<b>ECM600/040</b>	120/240	
	<b>400</b>	11	2.9	7.5		120.66/240.66		<b>400</b>	17	1.8	7.5		120.66/240.66	
	<b>300</b>	14	2.4	10				<b>300</b>	22	1.5	10			
	<b>200</b>	20	1.7	15				<b>200</b>	32	1.1	15			
	<b>150</b>	26	1.2	20				<b>150</b>	42	0.7	20			
	<b>120</b>	32	0.9	25				<b>120</b>	40	0.7	25			
	<b>100</b>	37	1.0	30				<b>100</b>	54	0.7	30			
	<b>75</b>	46	0.7	40				<b>75</b>	49	0.7	40			
	<b>60</b>	46	0.7	50				<b>600/050</b>	12	4.7	5		120/240	
	<b>50</b>	41	0.7	60		<b>ECM350/050</b>	120/240		<b>400</b>	17	3.3		7.5	120.66/240.66
	<b>38</b>	39	0.7	80	120.66/240.66			<b>300</b>	22	2.7	10			
	<b>30</b>	34	0.7	100				<b>200</b>	33	1.9	15			
	<b>200</b>	21	3.0	15				<b>150</b>	43	1.3	20			
	<b>150</b>	27	2.1	20				<b>120</b>	52	1.0	25			
	<b>120</b>	33	1.6	25				<b>100</b>	60	1.1	30			
	<b>100</b>	37	1.8	30				<b>75</b>	75	0.8	40			
	<b>75</b>	47	1.3	40				<b>60</b>	81	0.7	50			
	<b>60</b>	57	1.0	50				<b>50</b>	74	0.7	60			
	<b>50</b>	65	0.8	60				<b>38</b>	66	0.7	80			
	<b>38</b>	66	0.7	80	<b>ECM350/063</b>	120/240		<b>200</b>	33	3.5	15	120/240		
	<b>30</b>	61	0.7	100		120.66/240.66		<b>150</b>	43	2.4	20	120.66/240.66		
	<b>75</b>	48	2.3	40				<b>120</b>	53	1.8	25			
	<b>60</b>	58	1.8	50				<b>100</b>	60	2.1	30			
	<b>50</b>	67	1.5	60				<b>75</b>	77	1.4	40			
	<b>38</b>	83	1.1	80				<b>60</b>	93	1.1	50			
	<b>30</b>	96	0.8	100				<b>50</b>	107	0.9	60			
	<b>60</b>	59	2.5	50				<b>38</b>	132	0.7	80			
	<b>50</b>	69	2.1	60				<b>30</b>	114	0.7	100			
	<b>38</b>	85	1.5	80		<b>ECM350/070</b>	120/240		<b>120</b>	53	2.6	25	120/240	
	<b>30</b>	99	1.2	100	120.66/240.66			<b>100</b>	61	3.0	30	120.66/240.66		
								<b>75</b>	78	2.1	40			
								<b>60</b>	94	1.6	50			
								<b>50</b>	110	1.3	60			
								<b>38</b>	137	0.9	80			
								<b>30</b>	158	0.7	100			

N.B.  
Verificare sempre che la coppia M<sub>2</sub> utilizzata non ecceda il valore indicato nelle caselle in grigio  
N.B.  
Please check that the output torque M<sub>2</sub> does not exceed the value in the grey areas

**NOTA:** per servizio continuo o altamente intermittente, contattare il servizio tecnico  
**NOTE:** for continuous or highly intermittent duty, please contact our technical service

**Motori applicabili**

**Motor adapters**

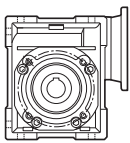
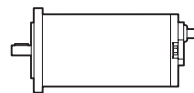

		EC						
		070.12E 070.24E	100.120 100.240 100.24E	180.120 180.240	180.24E	250.120 250.240	350.120 350.240	600.120 600.240
<b>CM</b>	<b>026</b>	5-60	5-60	5-60				
	<b>030</b>	5-100	5-100	5-100	5-50	5-50	5-50	
	<b>040</b>		5-100	5-100	5-100	5-100	5-100	5-40
	<b>050</b>			40-100 <sup>(1)</sup>	5-100	5-100	15-100	5-80
	<b>063</b>					40-100 <sup>(2)</sup>	40-100 <sup>(2)</sup>	15-100
	<b>070</b>						50-100 <sup>(3)</sup>	25-100 <sup>(3)</sup>

5-100

Rapporti di riduzione i  
Ratio i

(1): Solo IEC 63 B14  
63 B14 only

(3): Solo IEC 71 B5  
71 B5 only

(2): Solo IEC 71 B14  
71 B14 only





Dimensioni

Dimensions

ECM070/026 U

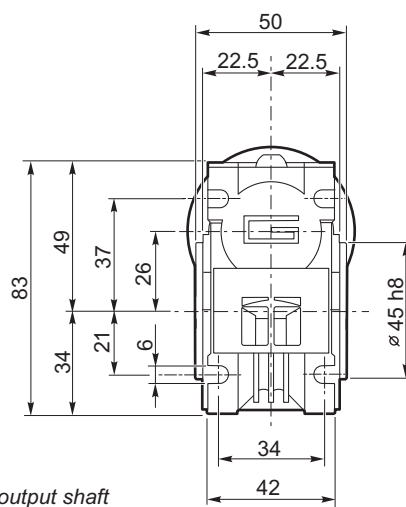
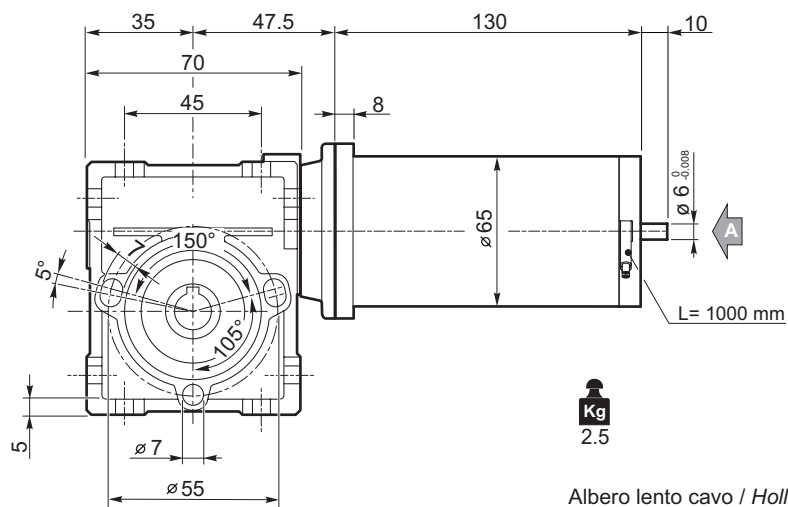

**Kg**  
2.5

Albero lento cavo / Hollow output shaft

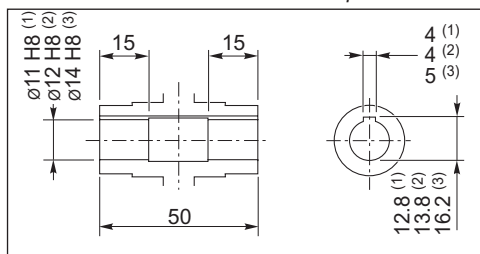

- (1): ECM 070/026 (D11)
- (2): ECM 070/026
- (3): ECM 070/026 (D14)

Vista da A  
View from A

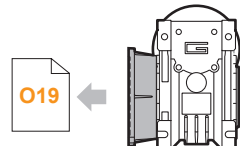
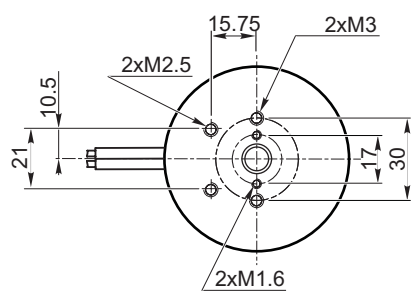

ECM070/026 F...

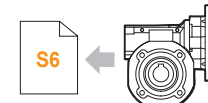

CL026

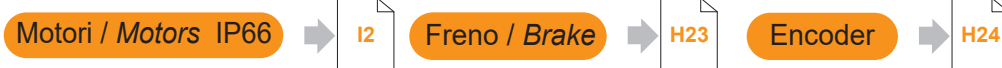

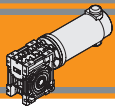

**Dimensioni**

**Dimensions**

**ECM070/030 U**

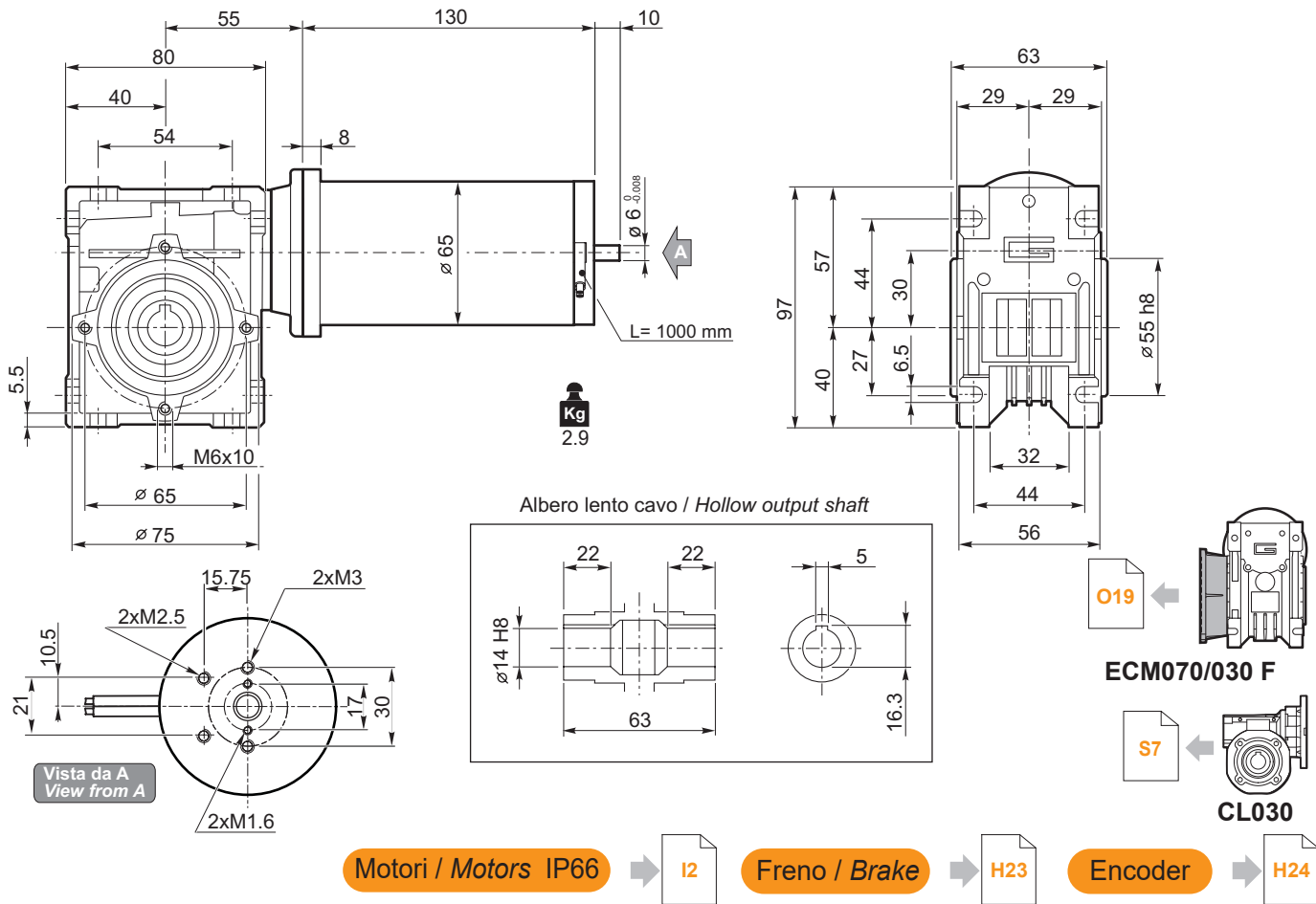

**ECM100/026 U**

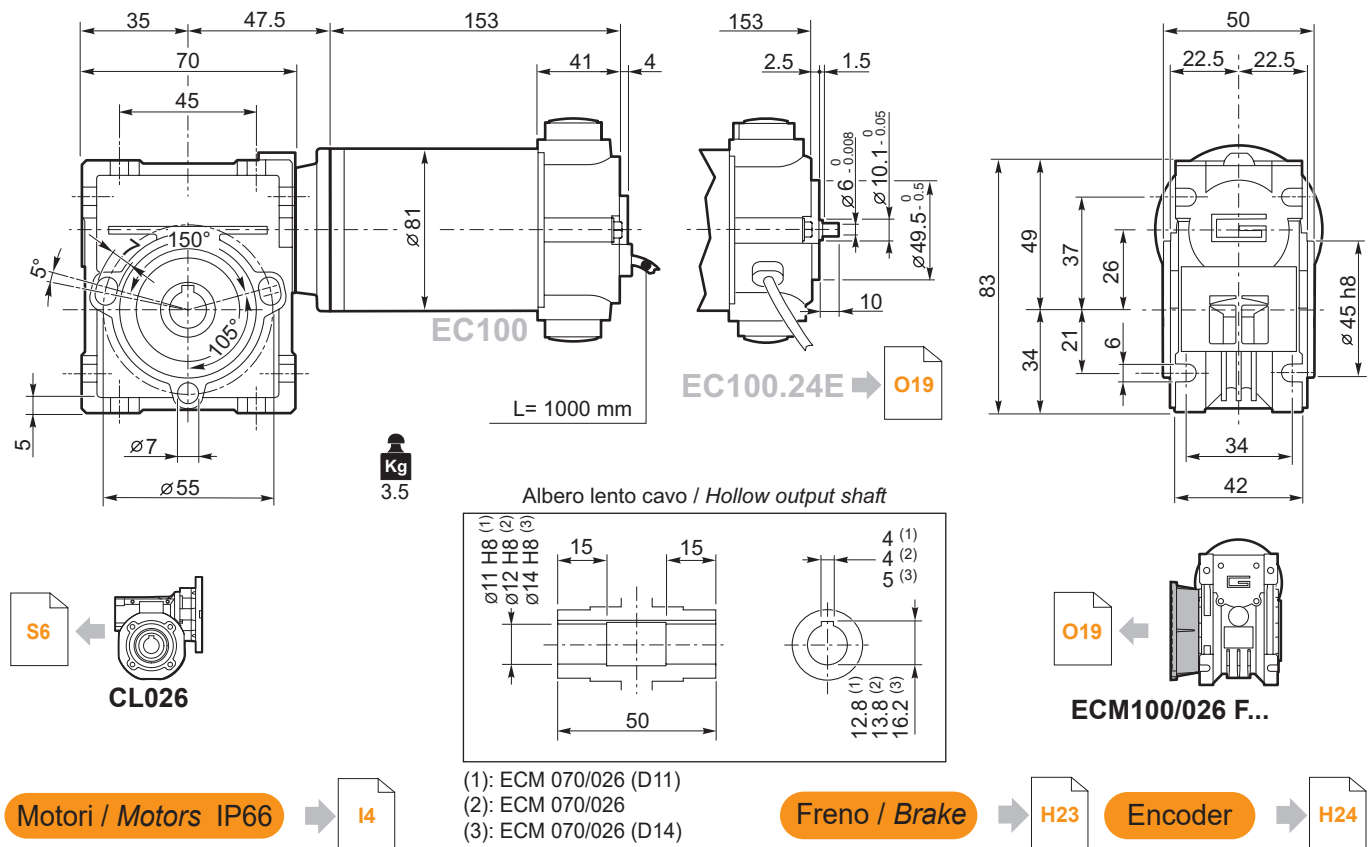



Dimensioni

Dimensions

ECM100/030 U

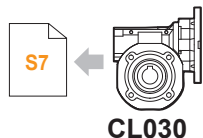
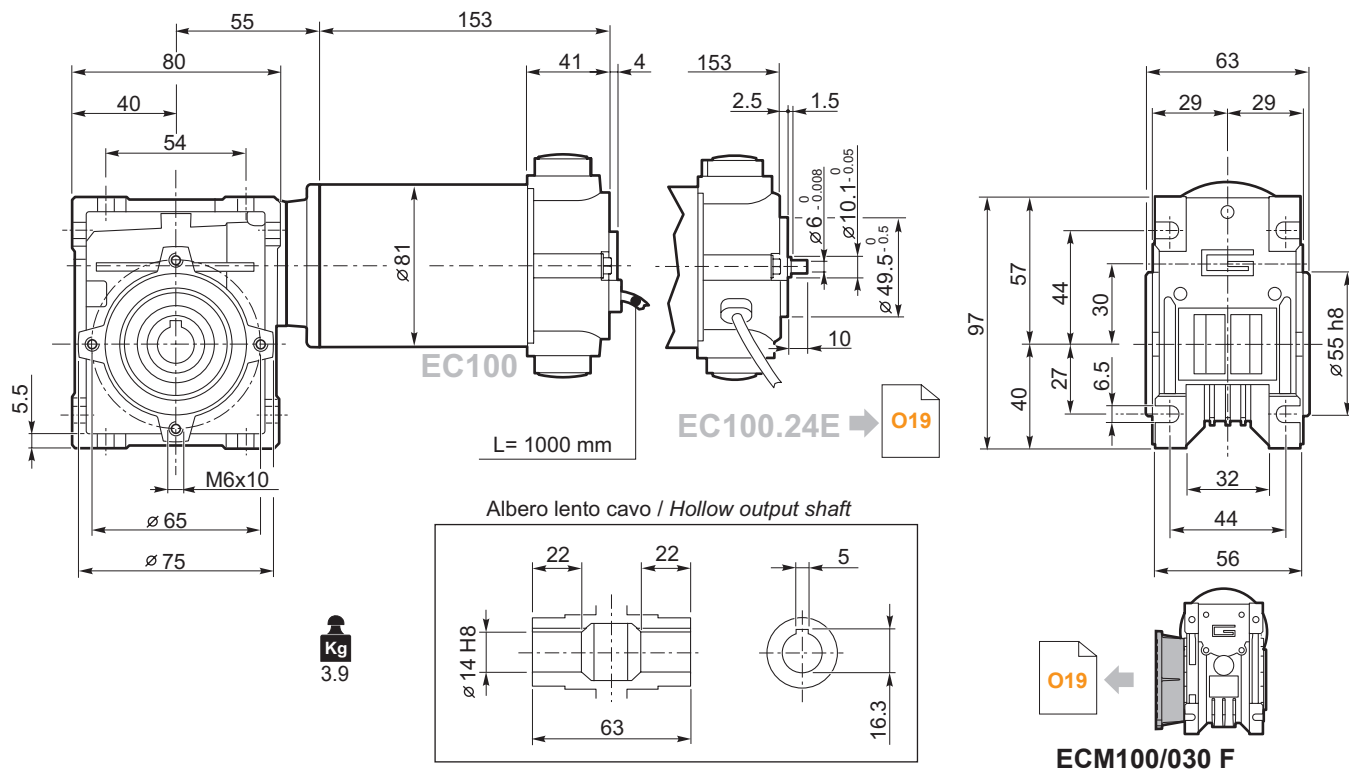

Motori / Motors IP66

I4

Freno / Brake

H23

Encoder

H24

ECM100/040 U

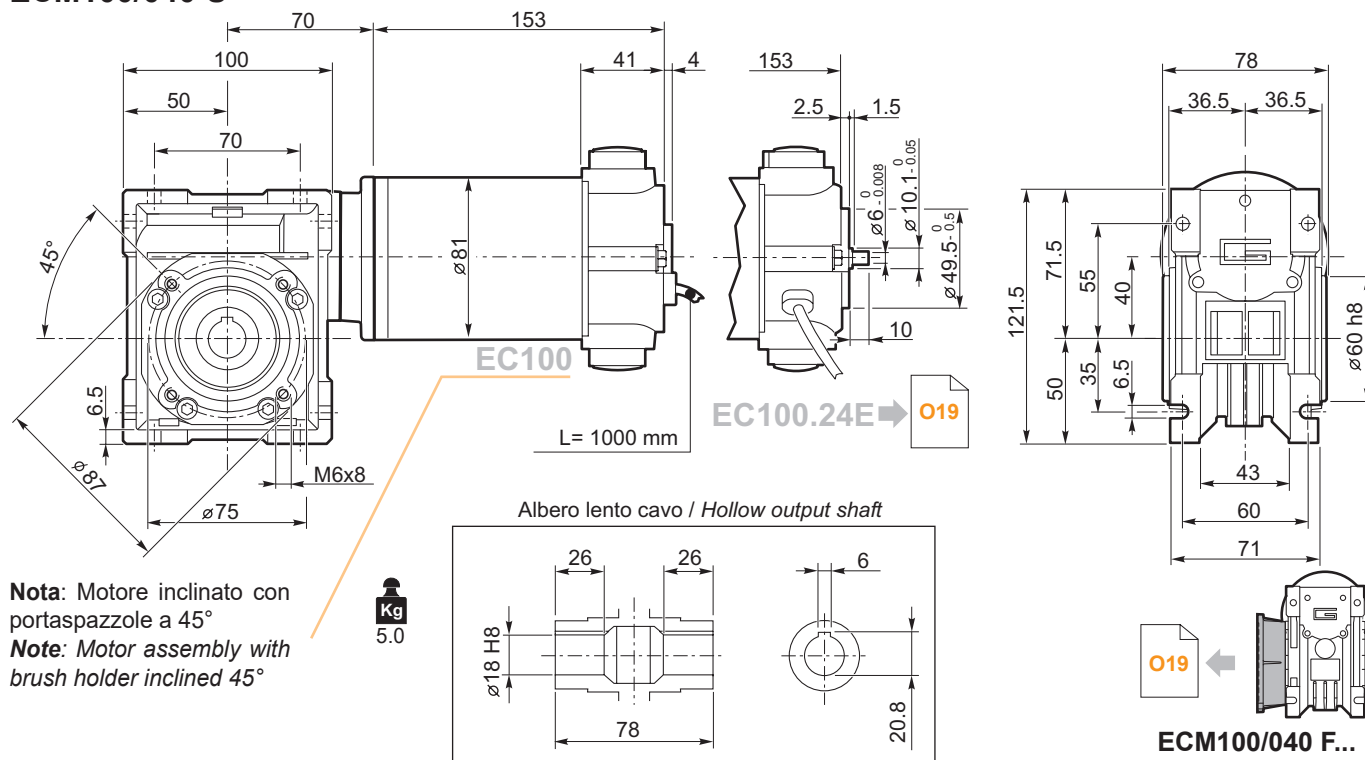

Nota: Motore inclinato con portaspazzole a 45°  
Note: Motor assembly with brush holder inclined 45°

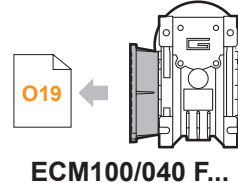

Motori / Motors IP66

I4

Freno / Brake

H23

Encoder

H24

S8

CL040

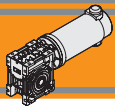

## Dimensioni

## Dimensions

### ECM180/026 U

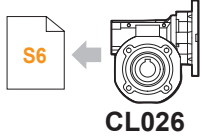
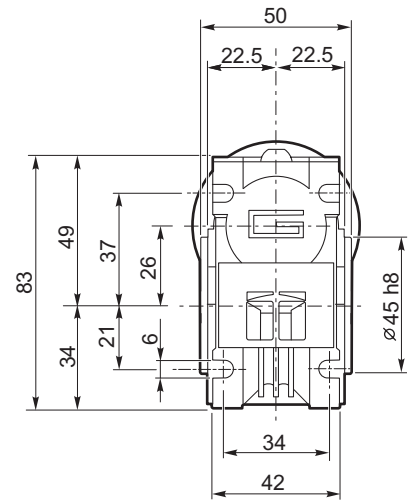
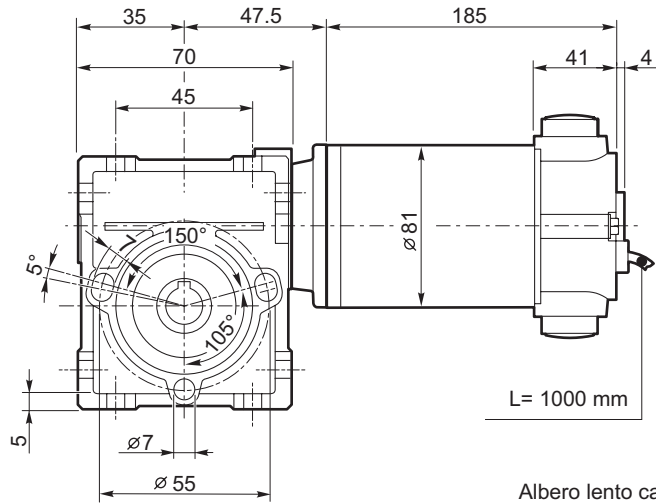

**Kg**  
4.2

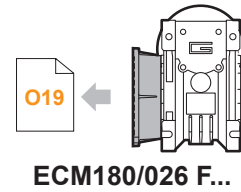
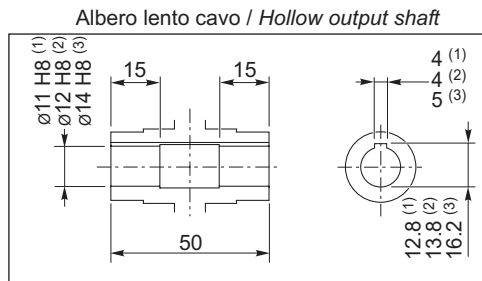

**Motori / Motors IP66**

**I6**

- (1): ECM 070/026 (D11)
- (2): ECM 070/026
- (3): ECM 070/026 (D14)

**Freno / Brake**

**H23**

**Encoder**

**H24**

### ECM180/030 U

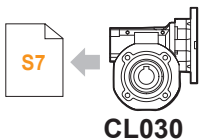
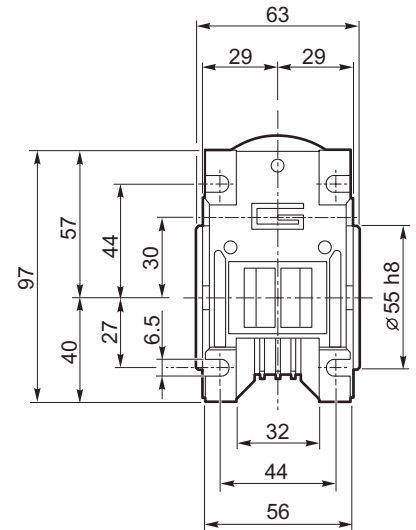
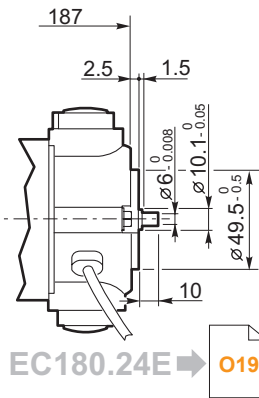
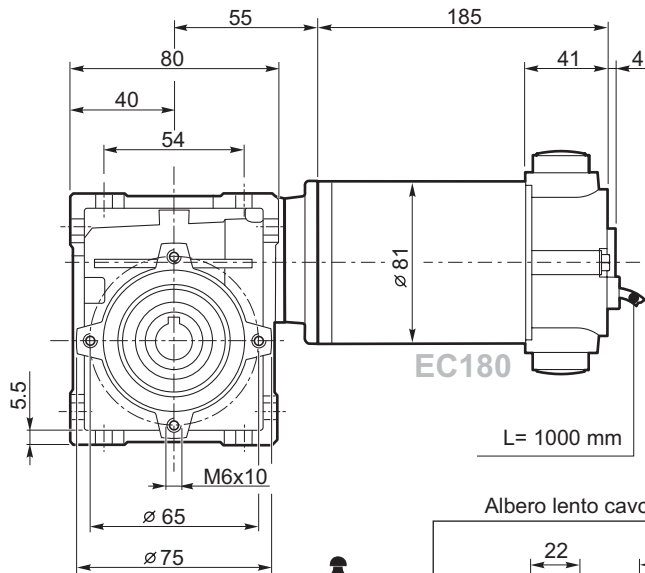

**Kg**  
4.6

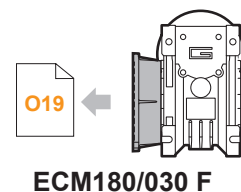
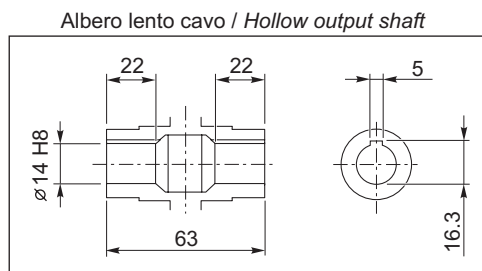

**Motori / Motors IP66**

**I6**

**Freno / Brake**

**H23**

**Encoder**

**H24**

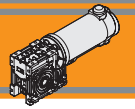

Dimensioni

Dimensions

ECM180/040 U

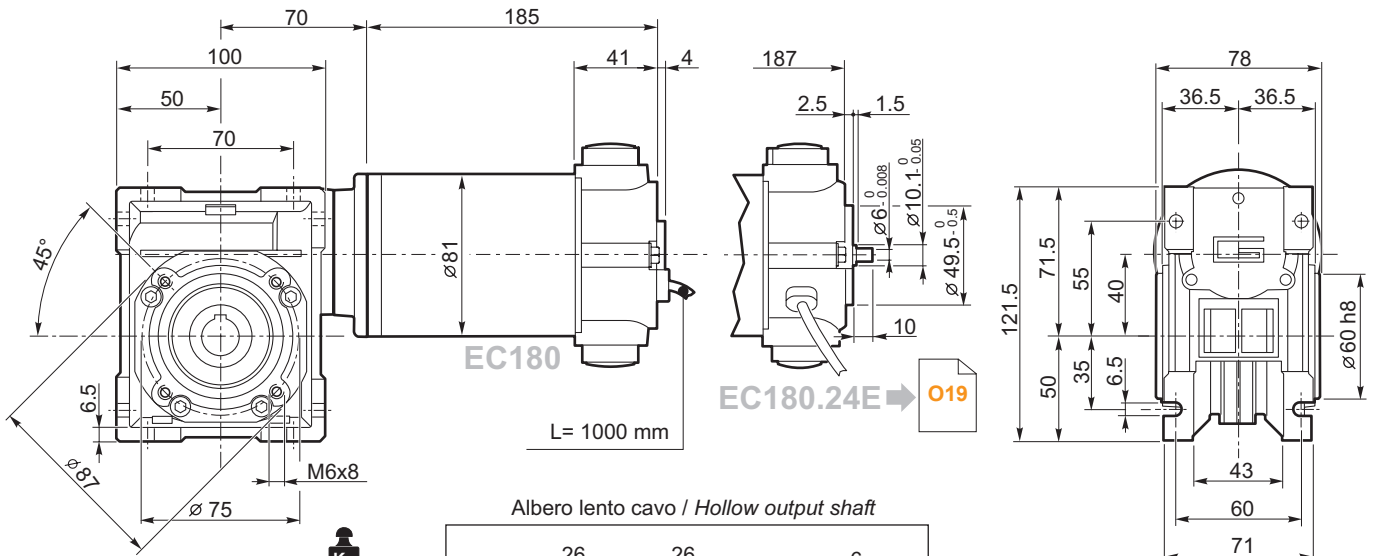

**Nota:** Motore inclinato con portaspazzole a 45°  
**Note:** Motor assembly with brush holder inclined 45°

**Kg**  
5.7

Albero lento cavo / Hollow output shaft

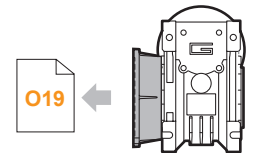
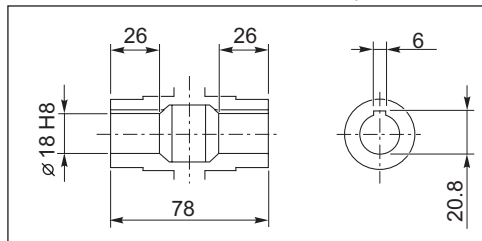

ECM180/040 F..

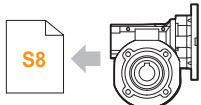

CL040

Motors / Motors IP66 → 16

Freno / Brake → H23

Encoder → H24

ECM180/050 U

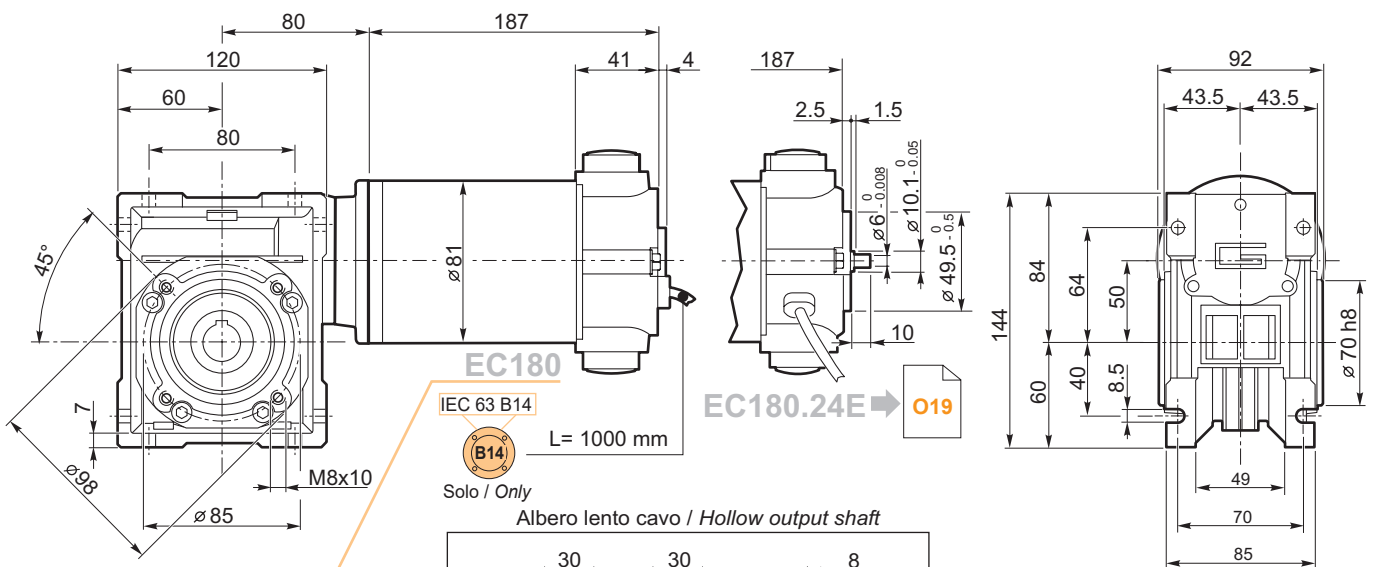

**Nota:** Motore inclinato con portaspazzole a 45°  
**Note:** Motor assembly with brush holder inclined 45°

**Kg**  
6.9

IEC 63 B14



Solo / Only

Albero lento cavo / Hollow output shaft

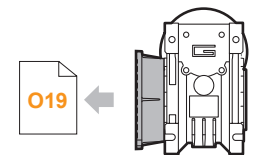
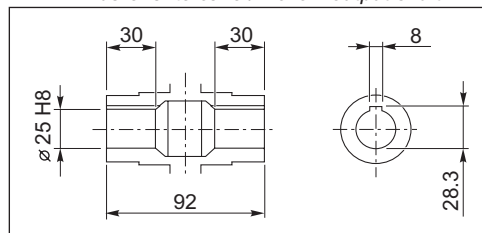

ECM180/050 F..

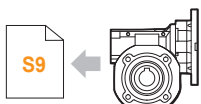

CL050

Freno / Brake → H23

Encoder → H24

ECM

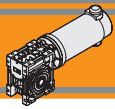

## Dimensioni

## Dimensions

### ECM250/030 U

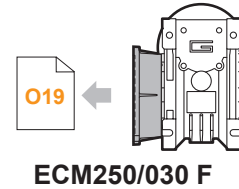
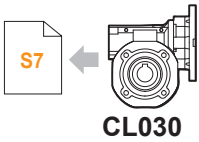
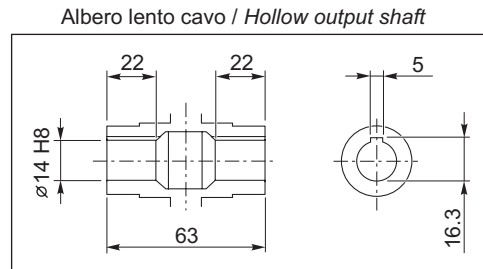
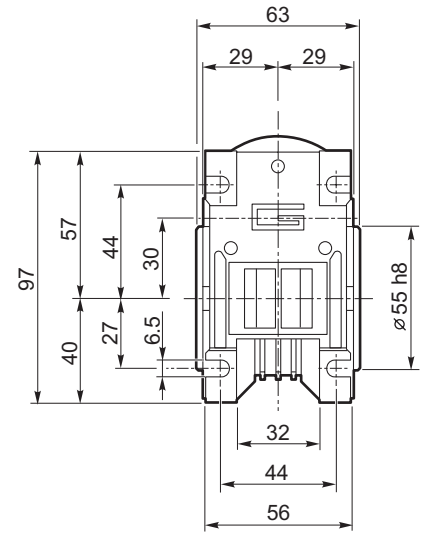
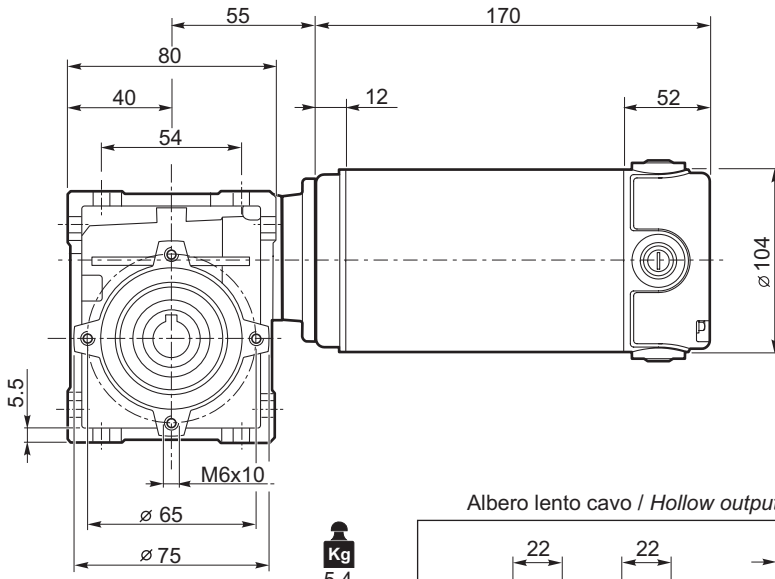

Motori / Motors IP66

18

### ECM250/040 U

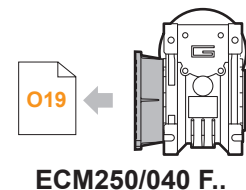
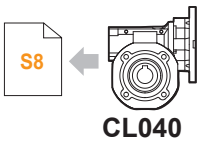
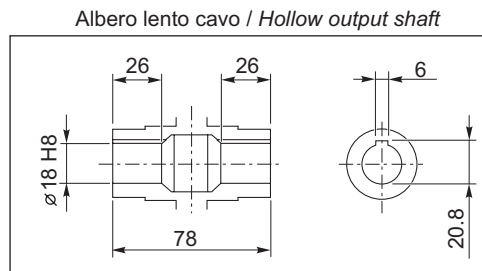
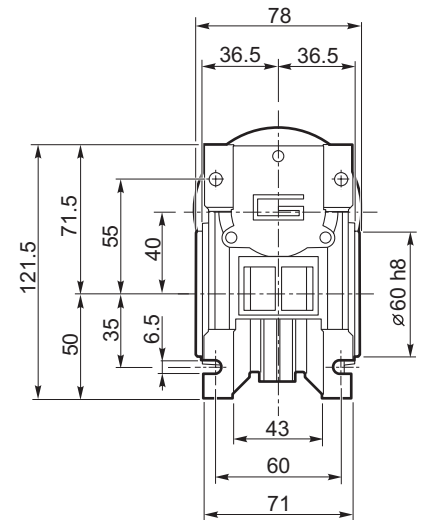
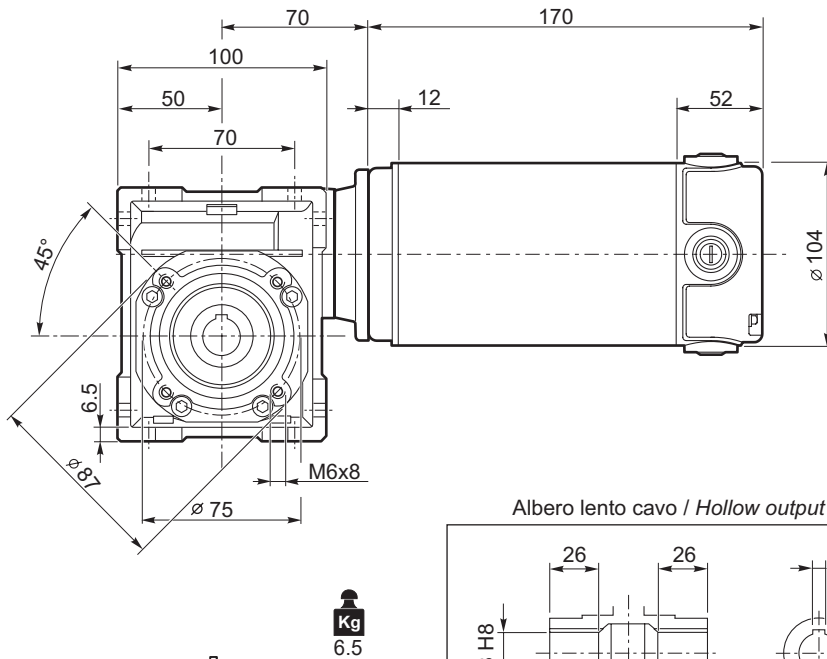

Motori / Motors IP66

18



Dimensioni

Dimensions

ECM250/050 U

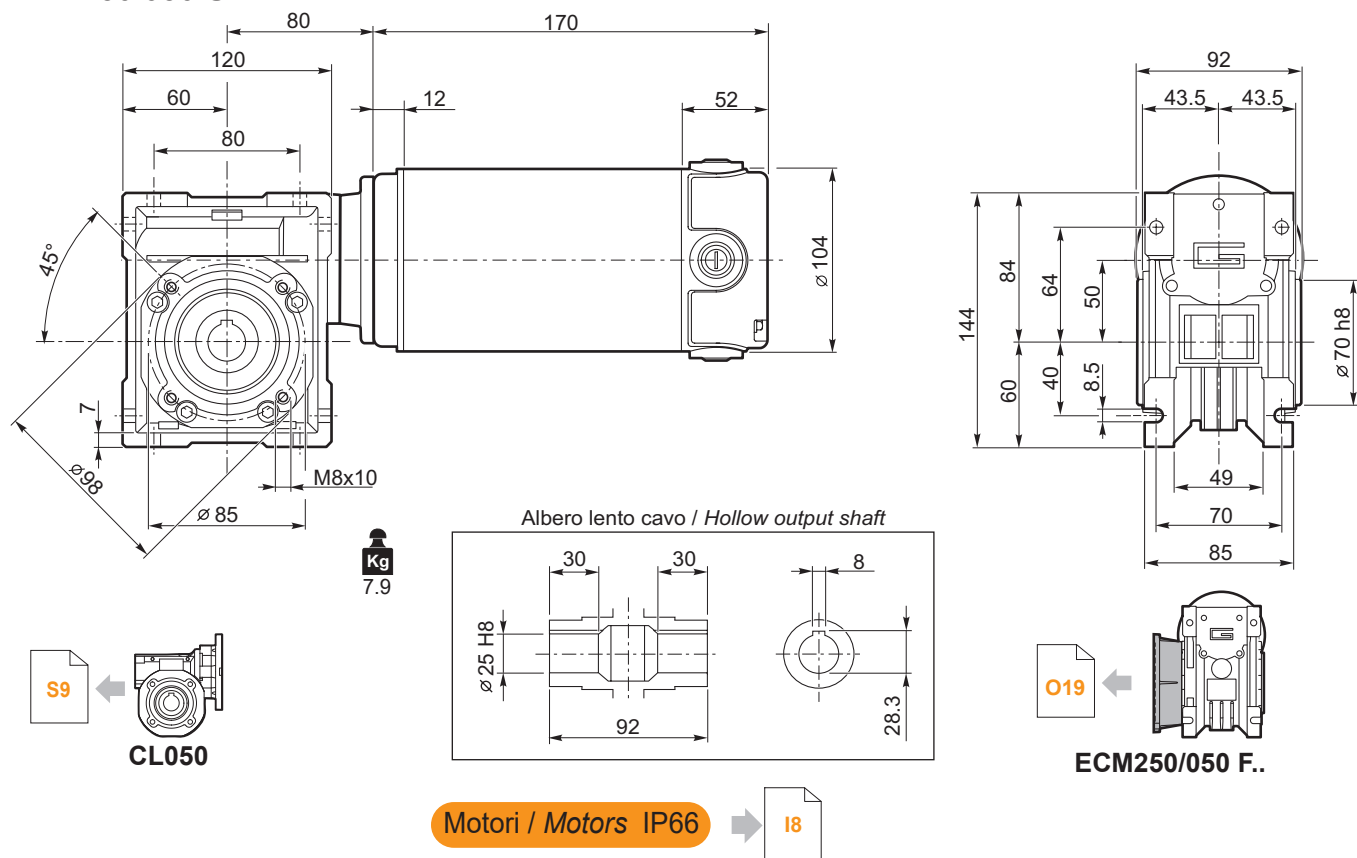

ECM250/063 U

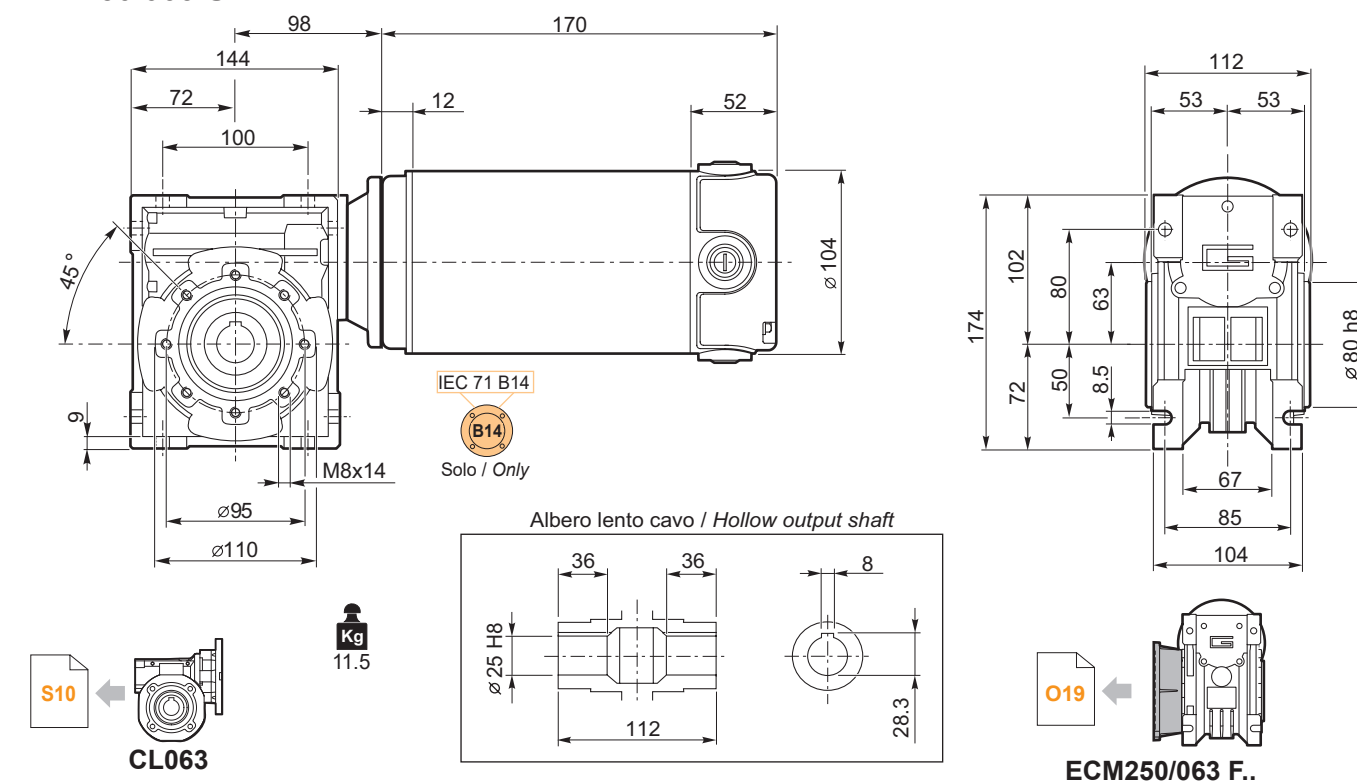

ECM

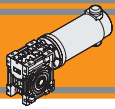

## Dimensioni

## Dimensions

### ECM350/030 U

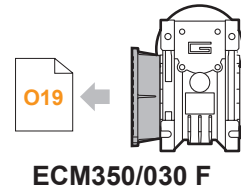
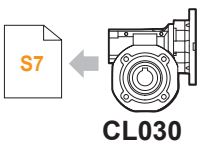
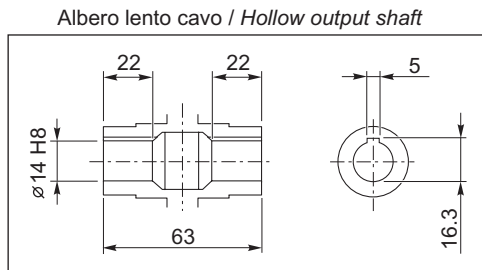
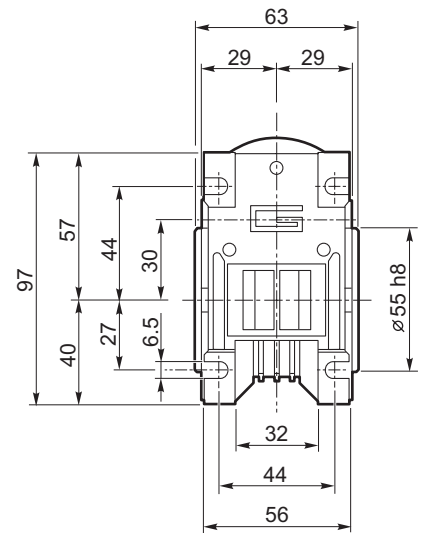
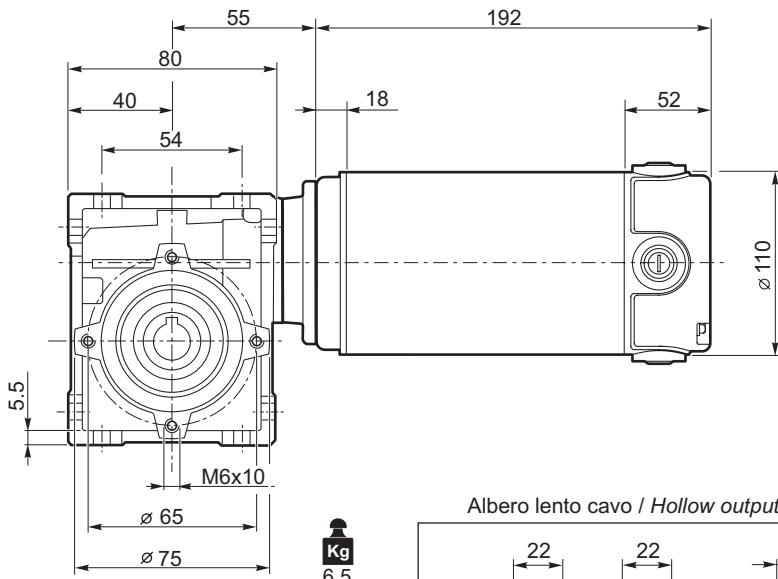

Motori / Motors IP66



Freno / Brake



### ECM350/040 U

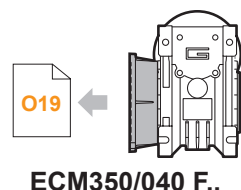
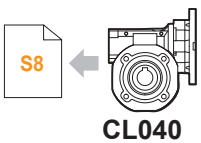
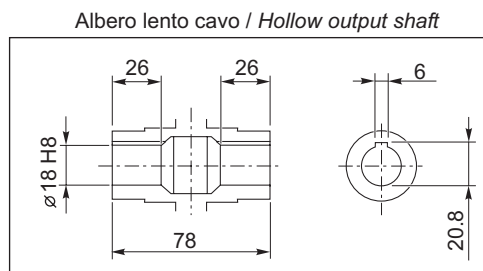
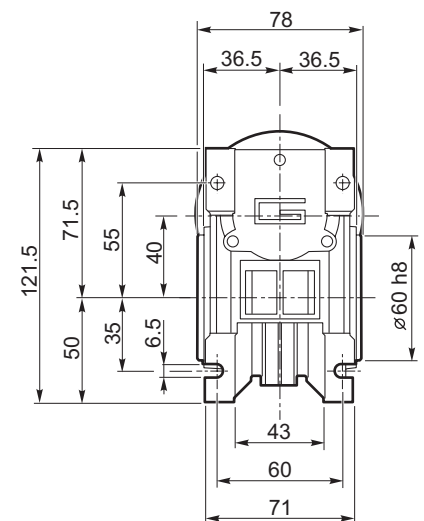
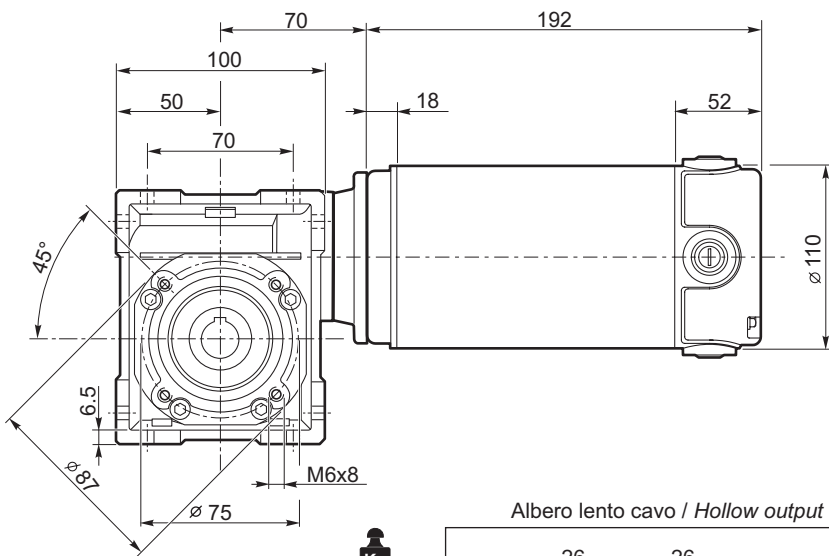

Motori / Motors IP66



Freno / Brake







Dimensioni

Dimensions

ECM350/050 U

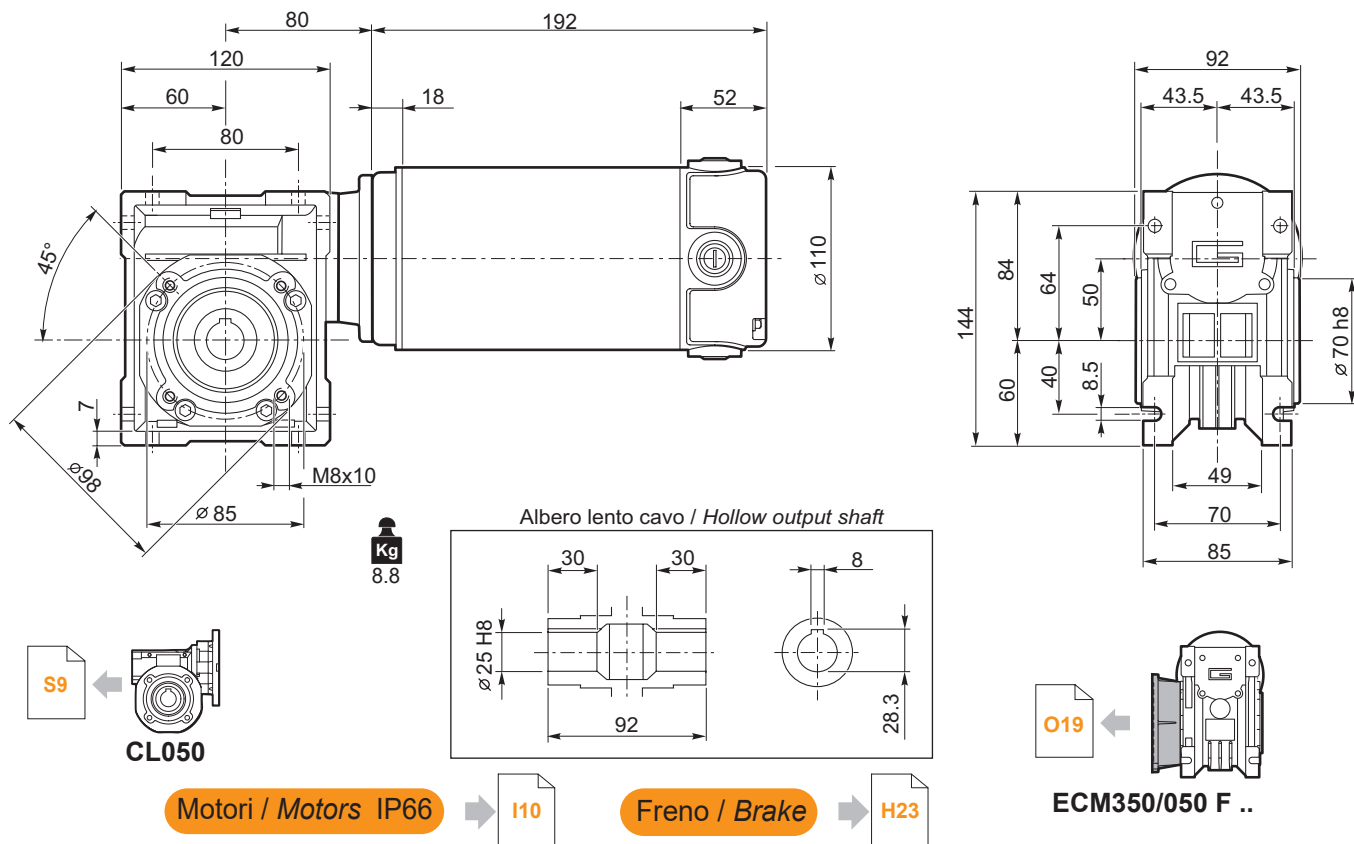

ECM350/063 U

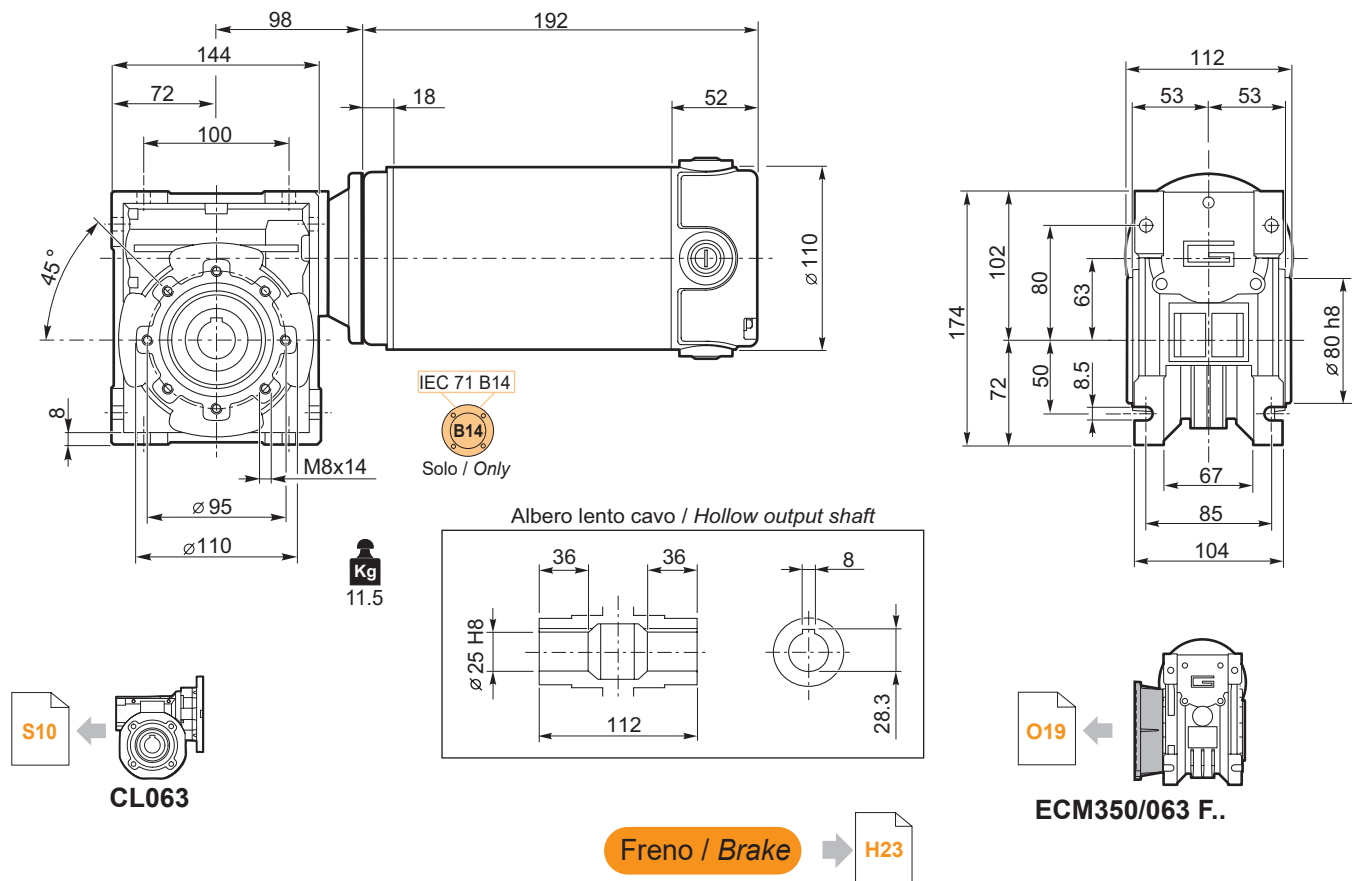

ECM

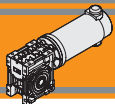

**Dimensioni**

**Dimensions**

**ECM350/070 U**

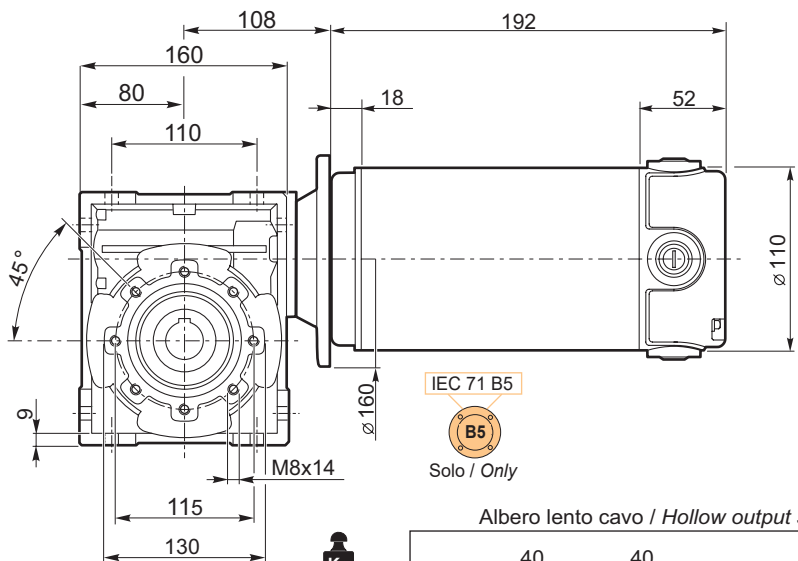

IEC 71 B5



Solo / Only

**Kg**  
12.8

Albero lento cavo / Hollow output shaft

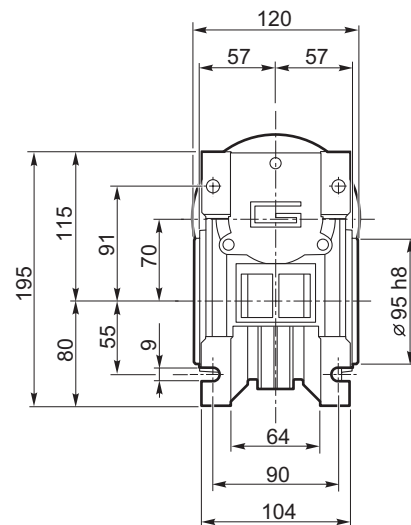
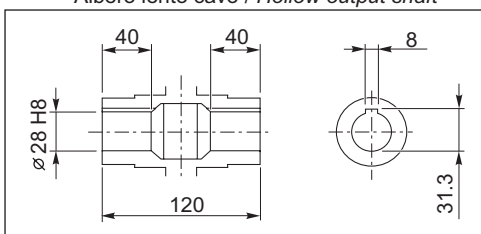

**CL070**



**ECM350/070 F**

**Freno / Brake**





Dimensioni

Dimensions

ECM600/040 U

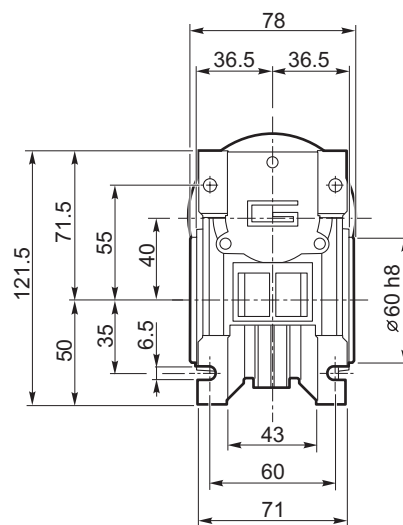
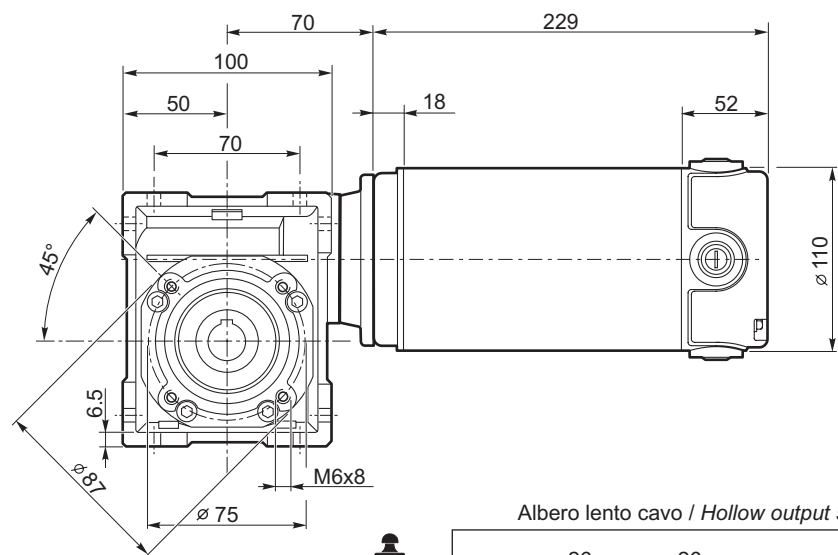

**Kg**  
9.4

Albero lento cavo / Hollow output shaft

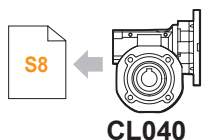
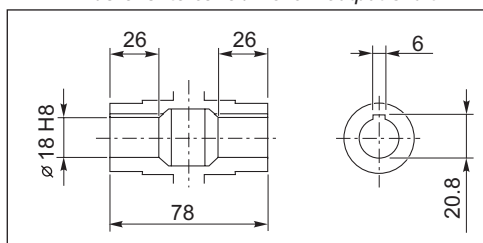

Motori / Motors IP66 → **I12**

Freno / Brake → **H23**

ECM600/050 U

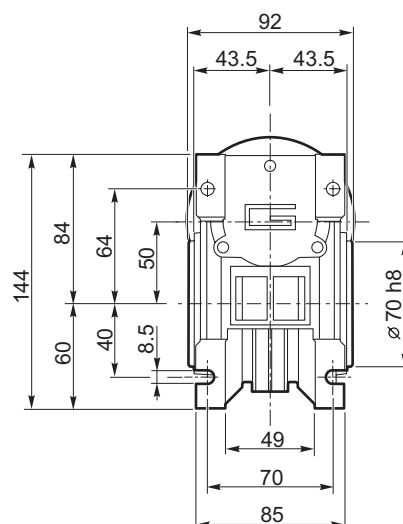
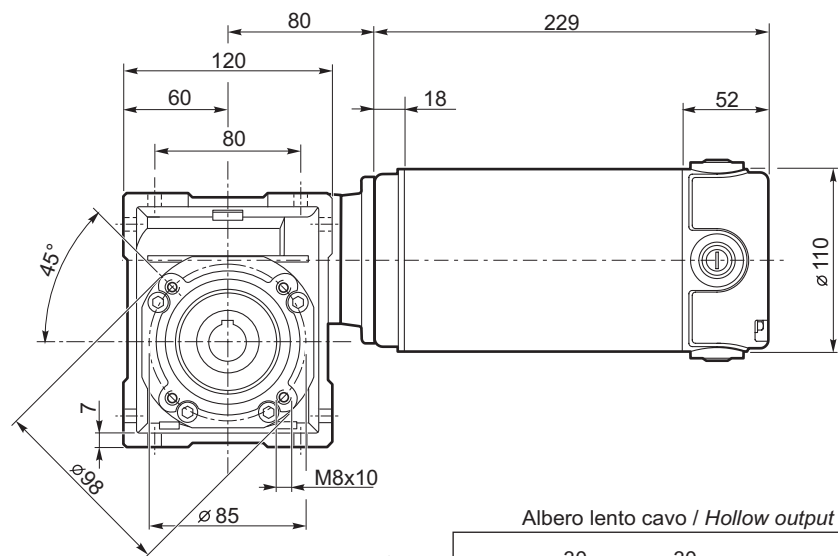

**Kg**  
10.6

Albero lento cavo / Hollow output shaft

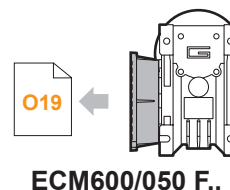
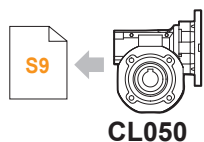
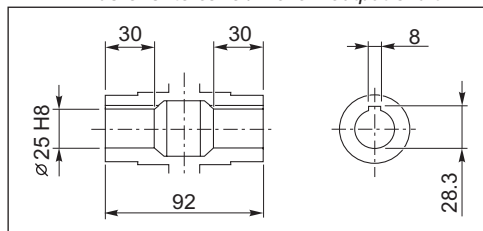

Motori / Motors IP66 → **I12**

Freno / Brake → **H23**

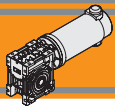

### ECM600/063 U

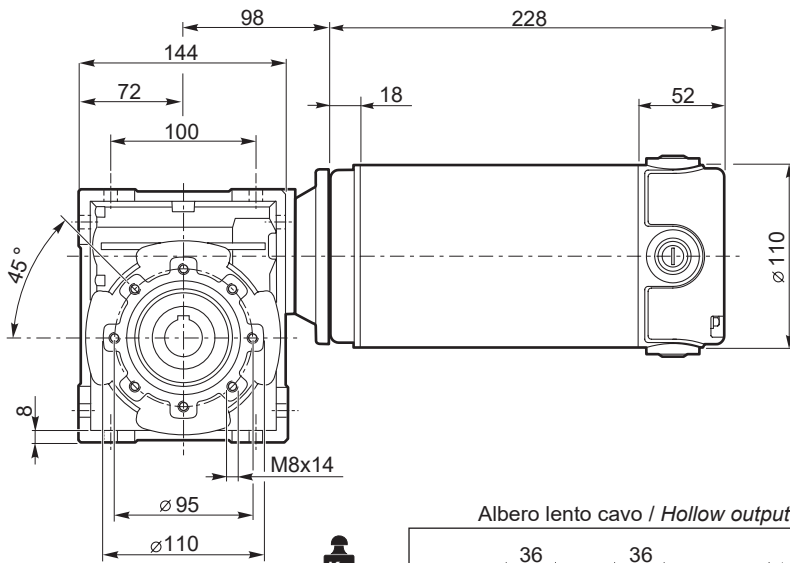

**Kg**  
13.3

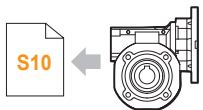

**CL063**

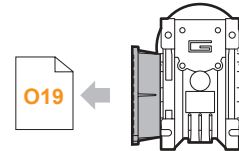
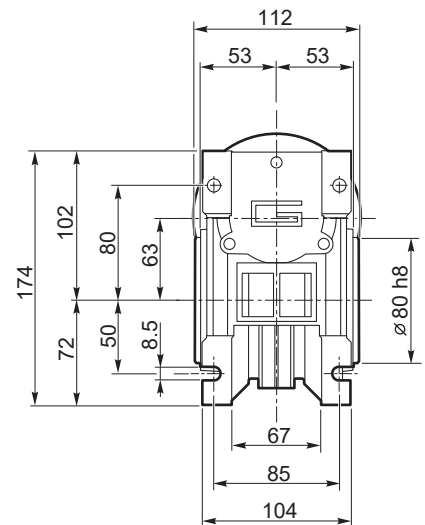
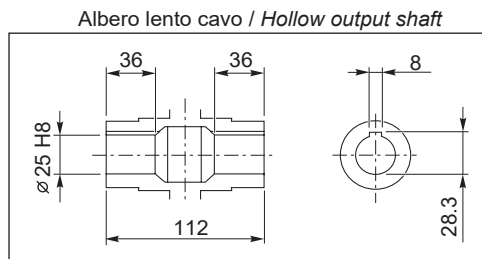

**ECM600/063 F..**

Motori / Motors IP66 →

I12

Freno / Brake →

H23

### ECM600/070 U

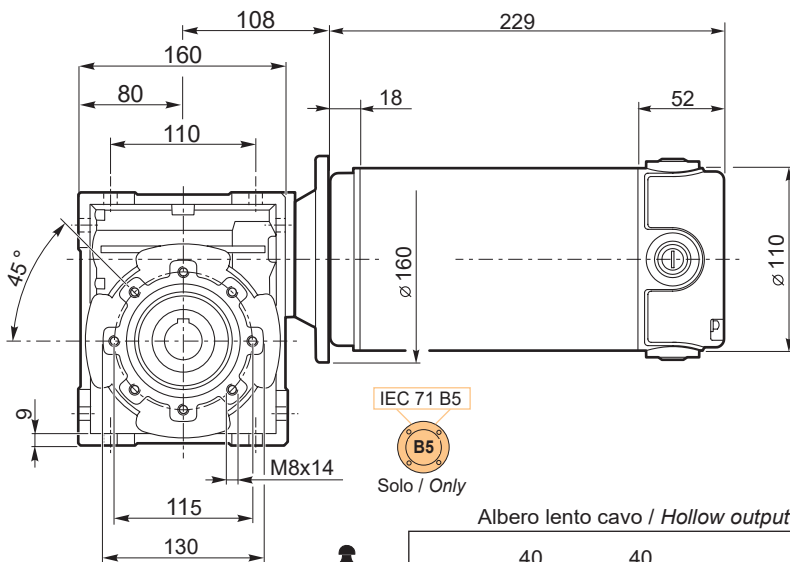

IEC 71 B5



Solo / Only

**Kg**  
14.6

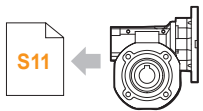

**CL070**

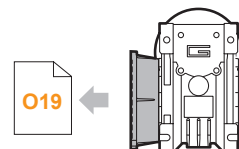
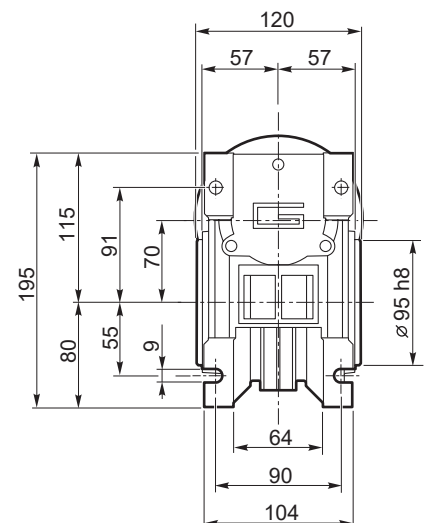
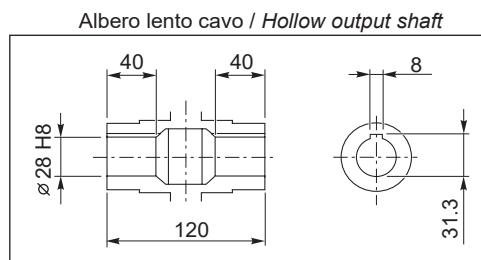

**ECM600/070 F**

Freno / Brake →

H23



Dimensioni

Dimensions

ECM.../... F... Flange uscita / Output flanges

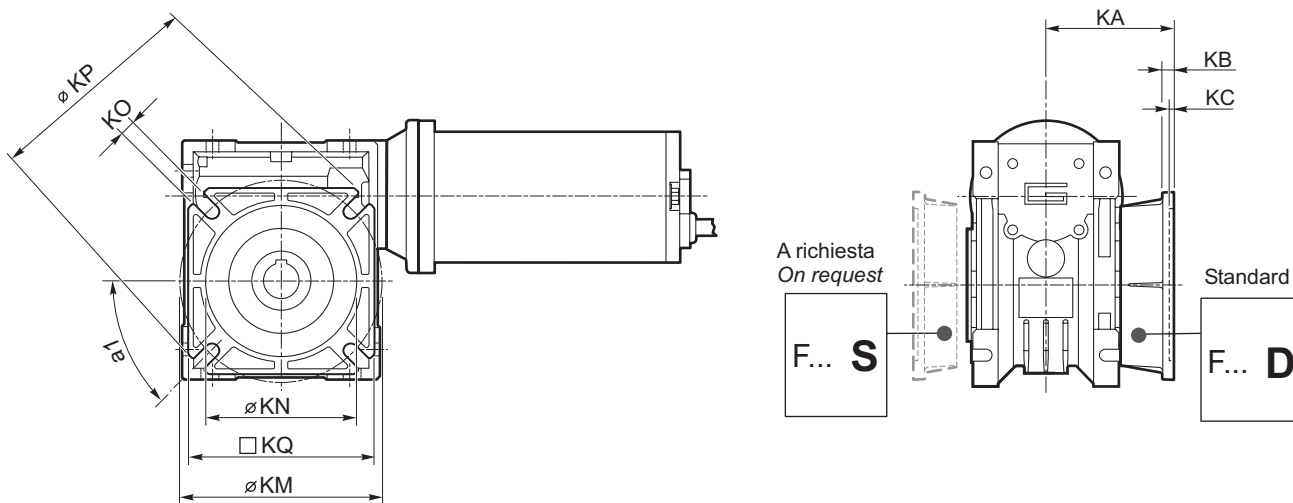

	CM..F							CM..F28							CM..F30										
	a1	KA	KB	KC	KM	KN <sub>H8</sub>	KO	KP	KQ	KA	KB	KC	KM	KN <sub>H8</sub>	KO	KP	KQ	KA	KB	KC	KM	KN <sub>H8</sub>	KO	KP	KQ
026 (D11) 026 026 (D14)	45°	45	6	4.5	55-69	40	6.5(n.4)	75	70	44	6.5	5	56-64	40	6.5	70	60	48	6.5	5	68	50	6.5	80	70

CM	CM..F							CM..FB							CM..FL										
	a1	KA	KB	KC	KM	KN <sub>H8</sub>	KO	KP	KQ	KA	KB	KC	KM	KN <sub>H8</sub>	KO	KP	KQ	KA	KB	KC	KM	KN <sub>H8</sub>	KO	KP	KQ
030	45°	54.5	6	4	68	50	6.5(n.4)	80	70	—	—	—	—	—	—	—	—	—	—	—	—	—	—	—	—
040	45°	67	7.5	4	80-95	60	9(n.4)	110	95	80	8.5	5	115-125	95	9.5(n.4)	140	112	97	7.5	4.5	80-95	60	9(n.4)	110	95
050	45°	90	9	5	90-110	70	11(n.4)	125	110	89	9	5	130-145	110	9.5(n.4)	160	132	120	9	5	90-110	70	11(n.4)	125	110
063	45°	82	10	6	150-160	115	11(n.4)	180	142	98	10	5	165-180	130	11(n.4)	200	160	112	10	6	150-160	115	11(n.4)	180	142
070	45°	107	13	6	165-180	130	14(n.4)	200	170	—	—	—	—	—	—	—	—	—	—	—	—	—	—	—	—

EC100.24E  
EC180.24E

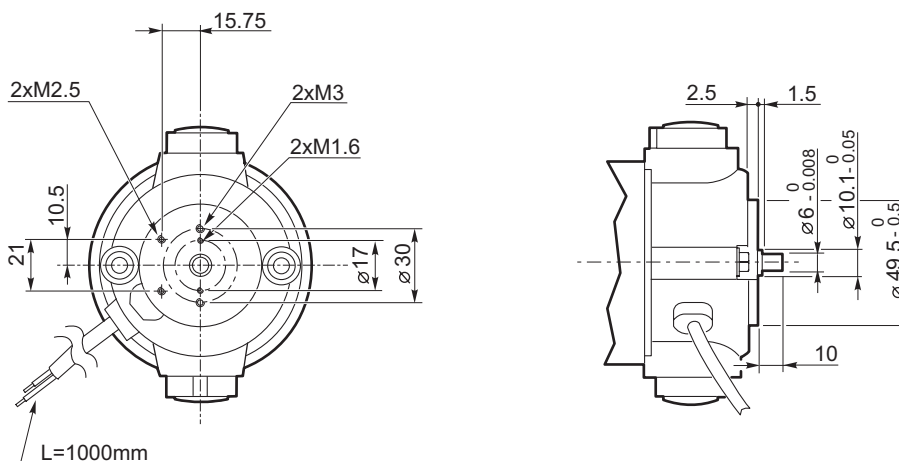

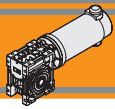

**VS - Vite sporgente / Extended input shaft**

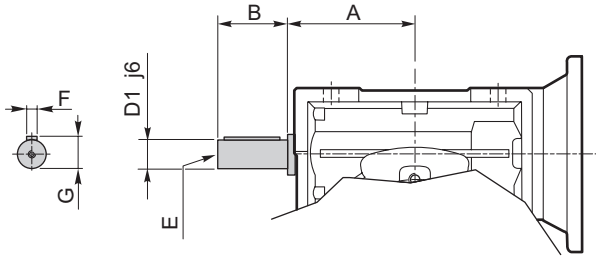

	A	B	D <sub>1</sub> j6	E	F	G
CM 030	45	20	9	M4	3	10.2
CM 040	53	23	11	M5	4	12.5
CM 050	64	30	14	M6	5	16
CM 063	75	40	19	M6	6	21.5
CM 070	84	40	19	M6	6	21.5

Costruito su richiesta  
Built on request

**SC - Safety cover**

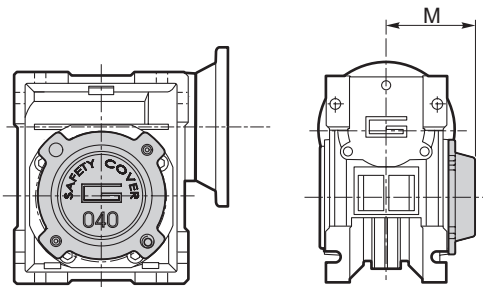

	M
CM 030	47
CM 040	54.5
CM 050	62.5
CM 063	73
CM 070	75

**WD - Washdown cover**

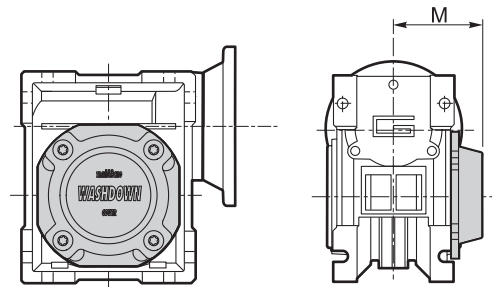

	M
CM 030	48
CM 040	55.5
CM 050	63.5
CM 063	71.5
CM 070	76



Accessori

Accessories

Albero lento

Output shaft

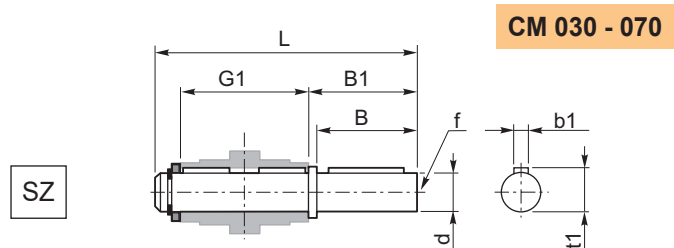
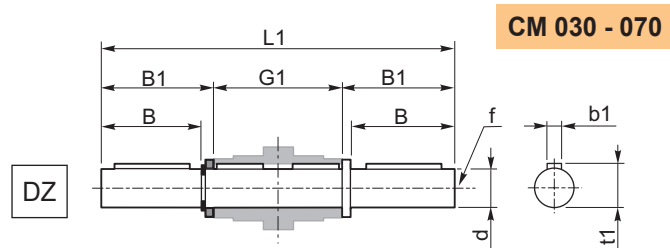

	d h7	B	B1	G1	L	L1	f	b1	t1
CM 030	14	30	32.5	63	102	128	M6	5	16
CM 040	18	40	43	78	128	164	M6	6	20.5
CM 050	25	50	53.5	92	153	199	M10	8	28
CM 063	25	50	53.5	112	173	219	M10	8	28
CM 070	28	60	63.5	120	192	247	M10	8	31

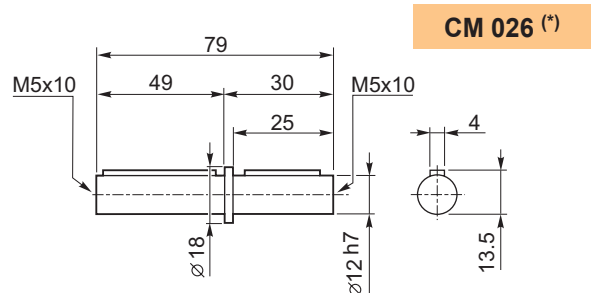

(\*)  
Nota: disponibile solo per cavo uscita Ø12  
Note: available for output hollow shaft Ø12 only

Braccio di reazione

Torque arm

	K1	G	KG	KH	R
CM 030	85	14	23	8	15
CM 040	100	14	31	10	18
CM 050	100	14	38	10	18
CM 063	150	14	47.5	10	18
CM 070	200	25	46.5	20	30

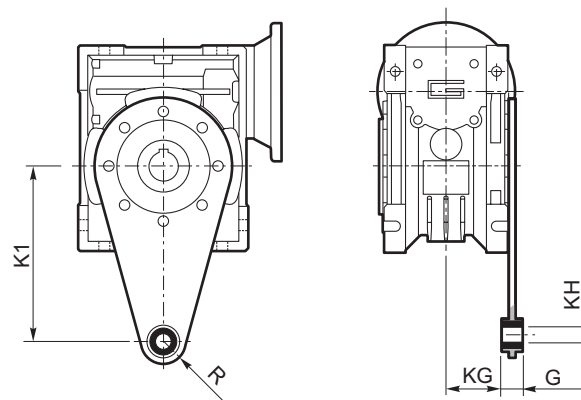





 **TRANSTECNO SRL**  
**HEADQUARTERS**

Company subject to the management  
and coordination of INTERPUMP GROUP SPA  
Via Caduti di Sabbiano, 11/D-E  
40011 Anzola dell'Emilia (BO)  
ITALY  
T+39 051 64 25 811  
F +39 051 73 49 43  
sales@transtecno.com  
[www.transtecno.com](http://www.transtecno.com)

**TRANSTECNO®**  
the modular gearmotor  
**MEMBER OF INTERPUMP GROUP**



 **HANGZHOU INTERPUMP  
POWER TRANSMISSIONS CO LTD**  
No.4 Xiuyan Road Fengdu Industry Zone  
Pingyao Town Yuhang District  
Hangzhou City, Zhejiang Province  
311115 – CHINA  
T +86 571 86 92 02 60  
info-china@transtecno.cn  
[www.transtecno.cn](http://www.transtecno.cn)

 **TRANSTECNO IBÉRICA  
THE MODULAR GEARMOTOR, S.A.**  
Carrer de la Ciència, 45  
08840 Viladecans (Barcelona) - SPAIN  
T +34 931 598 950  
info@transtecno.es  
[www.transtecno.es](http://www.transtecno.es)

 **TRANSTECNO B.V.**  
Siliciumweg 32  
3812 SX Amersfoort - NETHERLANDS  
T +31(0) 33 45 19 505  
info@transtecno.nl  
[www.transtecno.nl](http://www.transtecno.nl)

 **TRANSTECNO AANDRIJFTECHNIEK B.V.**  
Siliciumweg 32  
3812 SX Amersfoort - NETHERLANDS  
T +31 (0) 33 20 47 006  
info@transtecnoaandrijftechniek.nl  
[www.transtecnoaandrijftechniek.nl](http://www.transtecnoaandrijftechniek.nl)

 **MA TRANSTECNO S.A.P.I. DE C.V.**  
Julián Sepúlveda Dávila #107,  
Parque Industrial SG  
Apodaca, Nuevo León, CP. 66640  
MÉXICO  
T +52 8113340920  
info@transtecno.com.mx  
[www.transtecno.com.mx](http://www.transtecno.com.mx)

 **TRANSTECNO USA**  
8 Creek Parkway,  
Boothwyn PA 19061-8136 - UNITED STATES  
T +1 (610) 4970154

**TRANSTECNO USA – WEST COAST BRANCH**  
14561 Fryelands Blvd SE  
Monroe, WA 98272 - UNITED STATES  
T +1 360-863-1300  
usaoffice@transtecno.com  
[www.transtecno.com](http://www.transtecno.com)

 **TRANSTECNO CANADA**  
51 B Caldari Road Unit 10  
Vaughan, ON L4K 4G3 - CANADA  
T +1 905 761 0762  
canadaoffice@transtecno.com  
[www.transtecno.com](http://www.transtecno.com)

 **TRANSTECNO INDIA**  
#6A, Sipcot Industrial complex, Phase-1,Elasagiri Road  
Hosur – 635126 Tamilnadu - INDIA  
T +91 4344 274434  
M +91 81443 88800

**TRANSTECNO INDIA – NORTH BRANCH**  
Plot No: 3 A, Sector 2, IIE, Sidcul, Pantnagar  
U.S. Nagar, Uttarakhand – 263153 - INDIA  
indiaoffice@transtecno.com  
[www.transtecno.com](http://www.transtecno.com)

 **TRANSTECNO BRAZIL**  
Rua Gilberto de Zorzi, 525 Forqueta - CEP. 95115-730  
CX Postal 3544 Caxias do Sul RS – BRAZIL

**TRANSTECNO BRAZIL – SÃO PAULO BRANCH**  
R. Mafalda Barnabe Soliane, 314 – CEP. 13347-610  
Indaiatuba, São Paulo - BRAZIL  
T +55 19 3437 2520

**TRANSTECNO BRAZIL – PORTO ALEGRE BRANCH**  
Rua Dr. Freire Alemão 155 / 402 - CEP. 90450-060  
Auxiliadora Porto Alegre RS - BRAZIL  
T +55 51 4042 0916  
M +55 51 811 45 962  
braziloffice@transtecno.com  
[www.transtecno.com.br](http://www.transtecno.com.br)

 **INTERPUMP ANTRIEBSTECHNIK GMBH**  
Büro Stuttgart - GERMANY  
T +49 (0)171 4781909  
germanoffice@transtecno.com  
[www.transtecno.com](http://www.transtecno.com)

 **SALES OFFICE OCEANIA**  
Unit 5, 12 Nyholt Drive, Yatala 4207  
Queensland - AUSTRALIA  
T +61 07 3800 0103  
M +61 04 38060997

UNIT 9, 94 Boundary Rd, Sunshine West 3020  
Victoria - AUSTRALIA  
T +61 9312 4722  
oceaniaoffice@transtecno.com  
[www.transtecno.com.au](http://www.transtecno.com.au)